

BEFORE YOU GET STARTED...

We're confident you'll love your gorgeous new Next furniture. However, it's worth making absolutely certain before you put it all together.

So, let's quickly run through these three steps:

1. COLOUR

Make sure you're happy with the colour
No need to unpack everything, just check the first component.

2. PROTECTIVE PACKAGING

If you're happy, then it's time to get opening! Start by laying everything out on the protective packaging – this will prevent anything getting scratched.

3. PARTS PAGE

Finally, double check you have all the pieces by referencing the parts page of the instructions.

TIPS FOR RETURNS

Not completely happy with the product? No problem. We just need everything back in the original packaging, so follow the steps below and this will ensure a super-smooth returns process and no delay to your refund.

DO



- Check everything is there (the 'parts page' is a handy checklist).
- Pop all the loose fittings and fixtures into the packaging provided or tie them up in a plastic bag.
- Wrap all the big components back up in the original protective packaging.
- Close up the box and seal it securely (don't be afraid to use plenty of tape).

DON'T



- Leave anything assembled - all components should be dismantled and separately packed.
- Put loose fixtures and fittings straight into the box.
- Throw it back in the box carelessly – as it may get damaged.

next
HOME

Then just give us a call on 0333 777 8999 and we'll sort out a pick up time for you.

next

HUXLEY MIRROR

108487

Assembly instructions

Actual product size
H54 x W75 x D13cm

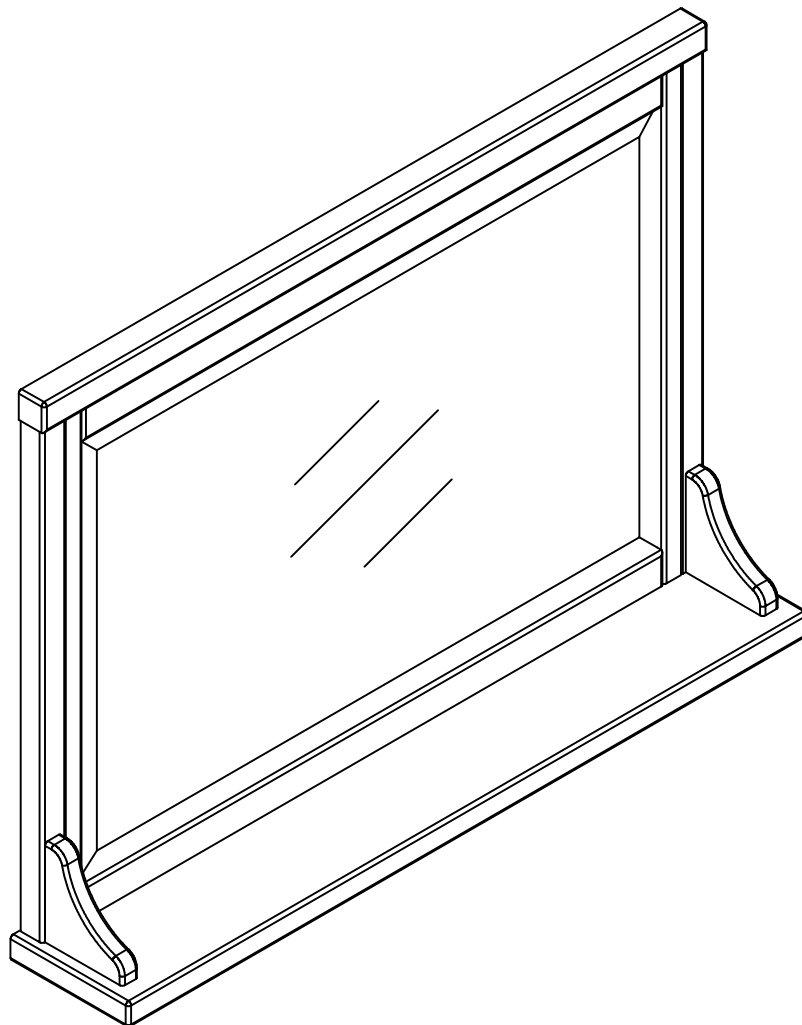

Need Help?

With: Assembly instructions
Missing or damaged parts

CALL: 0333 777 8999

IMPORTANT – RETAIN FOR FUTURE REFERENCE

BEFORE YOU START

Warnings

Important: Retain these instructions for future reference

We strongly recommend that a professional who has experience of fitting such items should install large mirrors.

Mirrors are heavy objects and your safety is dependant on the construction/ strength of the wall to which it is attached.

Wall fixings must be used for stability on this item and for safety reason the mirror should not be left freestanding.

NB: Wall fixings are not included - please source suitable fixing for your wall type. If in doubt please consult a qualified tradesperson.

If you need to return this mirror, please use the packaging provided.

Do's

We suggest you spend a short time reading through this leaflet before you start

When you are ready to start, make sure that you have the right tools. Plenty of space and a clean, dry area for assembly

Check the pack and make sure you have all the parts listed

During assembly children should be kept away from the product due to possible risk of injury

Always ensure intended wall area to be drilled is free from any hidden electrical wires, water and gas pipes.

Please use suitable wall fixings for your wall type

Please remove the plastic transit spacers from between the mirror sections before use.

To clean wipe with a sponge and warm soapy water. Do not use solvent based cleaners or detergents as they can bleach or damage the product.

BS7449: 1991

Name and Address: NEXT RETAIL LTD. LE19 4AT
identification and model Number: 108487 HUXLEY MIRROR

Date of Manufacture: 11/2016

Contract number: IM8438205

Nominal thickness of Glass: 5mm, Annealed glass

Country of Origin: China

If a glass component is chipped or broken replace with glass of the type described on this label. Consult with the retailer with regard to obtaining a manufacturing specification and shape for replacement glass quoting the model number, batch number and date of manufacture.

Don'ts

Do not place very hot or very cold items against or in close proximity to glass surface.

Do not strike the glass with hard or pointed items.

Do not use washing powders or any other substance containing abrasive since these substances

Do not use this product if parts are missing, damaged or worn.

Do not use wire between the two fixing brackets on the frame- only hang by screwing a permanent screw into a secure wall (as outlined below)

Do not use wire between the two fixing brackets on the frame- only hang by screwing a permanent screw into a secure wall (as outlined below)

Not suitable for use in bathrooms.

Number of people required to assemble

Need two people to lift the unit into position.

Time to assemble

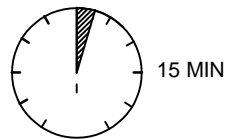

Tips

Look out for the symbol throughout this manual. Wherever you see it we will have a handy tip to help you with the assembly of your product.

Tools required



not supplied

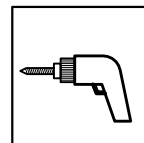

not supplied

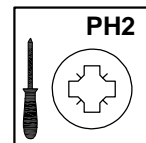

not supplied

Missing parts

If you are missing any fixtures and fittings for your product, please contact our customer service team on **0333 777 8999** and they will be happy to arrange for a replacement to be sent to you free of charge.

Home service technicians

If you have a fault with your product, please contact our customer service team on **0333 777 8999**. If you have had the product for 28 days or less you may be offered a replacement, refund or for a fully trained home service technician to visit your home to assess the fault and repair the product where possible. If you have had the product for more than 28 days we will send an independent home service technician to review and repair the product where possible and recommend further action.

You can write to us at

Home customer services
Next Retail Ltd,
Desford Road,
Leicester,
LE19 4AT

To view our full furniture range please visit www.next.co.uk

Components supplied

Ref	Dimensions	Visual	Qty
1	54×75×13cm		1

Fixtures and fittings supplied

Ref	Visual	Qty
A		1

1

Please use the template (A) provided to mark on the wall the position of the fixings.

NB: Place the template over the back of the mirror to ensure that the holes match the position of the hooks before drilling into your wall.

Use a spirit level to check that the fixings are level.



not supplied

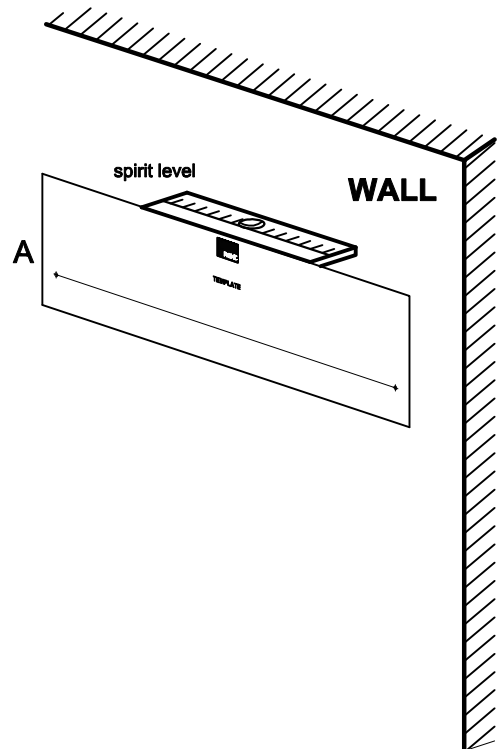

2

Drill two holes and insert an appropriate wall plug into each. Insert the screws and tighten, leaving the screw head exposed by about 1/4 inch (6mm).
WARNING: Always ensure intended wall area to be drilled is free from hidden electrical wires, water and gas pipes.

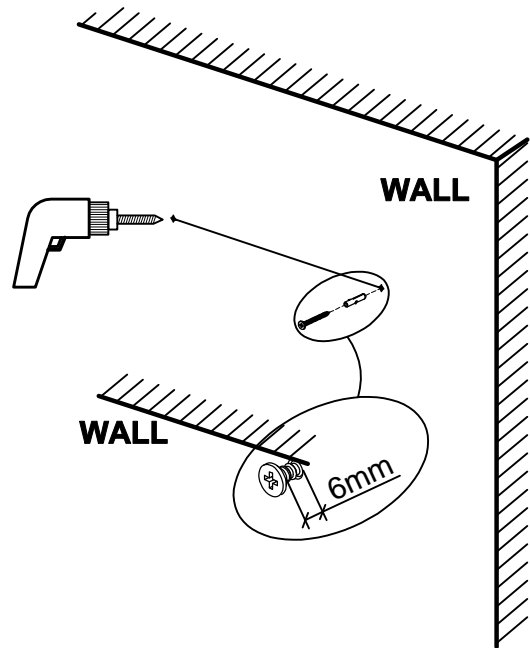

not supplied

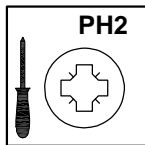

not supplied

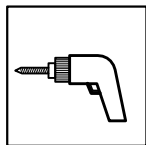

not supplied

3

Lift the mirror into position ensuring that the fixing clips attached to the mirror are firmly hooked over the screw heads. Check the mirror periodically to see that no fitting has loosened and needs attention.

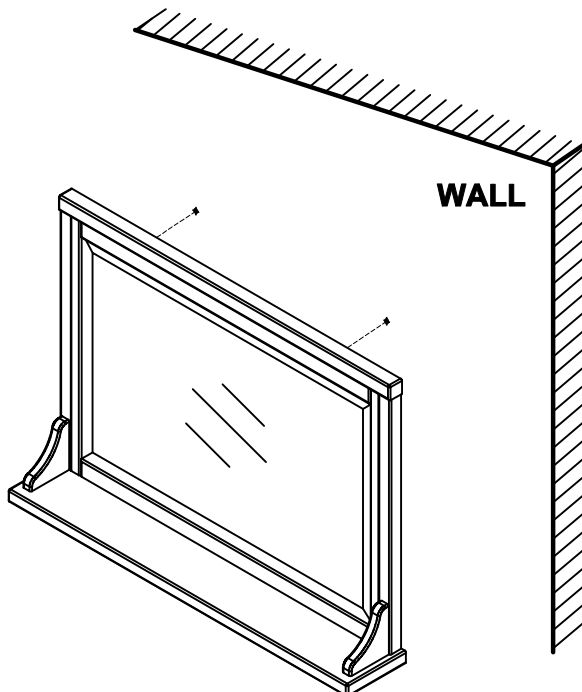



HUXLEY MIRROR

108487
Assembly instructions

Warnings

We suggest you retain these instructions for future reference.

Keep fittings out of children's reach and keep children well away from the construction area .

This product should only be used on firm,level ground.

Please periodically check all fittings and re-tighten as necessary.

Please do not sit or stand on your furniture.

Avoid exposing the furniture to excessive heat or direct sunlight as this can cause deterioration of the colour.

Unwrap all packaging materials and place the components on top of the carton box or on a clean floor to protect it from damage.

Missing parts

If you are missing any fixtures and fittings for your product please contact our customer service team on **0333 777 8999** and they will be happy to arrange for a replacement to be sent to you free of charge.

Home service technicians

If you have a fault with your product please contact our customer service team on **0333 777 8999** If you have had the product for 28 days or less you may be offered a replacement, refund or for a fully trained home service technician to visit your home to assess the fault and repair the product where possible. If you have had the product for more than 28 days we will send an independant home service technician to review and repair the product where possible and recommend further action.

You can write to us at Home Customer Services

Next Retail Ltd,
Desford Road,
Leicester,
LE19 4AT

To view our full furniture range please visit www.next.co.uk