

# BEFORE YOU GET STARTED...

*We're confident you'll love your gorgeous new Next furniture. However, it's worth making absolutely certain before you put it all together.*

*So, let's quickly run through these three steps:*

## 1. COLOUR

Make sure you're happy with the colour  
No need to unpack everything, just check the first component.

## 2. PROTECTIVE PACKAGING

If you're happy, then it's time to get opening! Start by laying everything out on the protective packaging – this will prevent anything getting scratched.

## 3. PARTS PAGE

Finally, double check you have all the pieces by referencing the parts page of the instructions.

## TIPS FOR RETURNS

Not completely happy with the product? No problem. We just need everything back in the original packaging, so follow the steps below and this will ensure a super-smooth returns process and no delay to your refund.

DO



- Check everything is there (the 'parts page' is a handy checklist).
- Pop all the loose fittings and fixtures into the packaging provided or tie them up in a plastic bag.
- Wrap all the big components back up in the original protective packaging.
- Close up the box and seal it securely (don't be afraid to use plenty of tape).

DON'T



- Leave anything assembled - all components should be dismantled and separately packed.
- Put loose fixtures and fittings straight into the box.
- Throw it back in the box carelessly – as it may get damaged.

next  
HOME

Then just give us a call on 0333 777 8999 and we'll sort out a pick up time for you.

next

# HOTEL HEADBOARD

130430 / 123511 / 145133

Assembly Instructions

**Actual product size**  
H60 x W120 x D8 CM

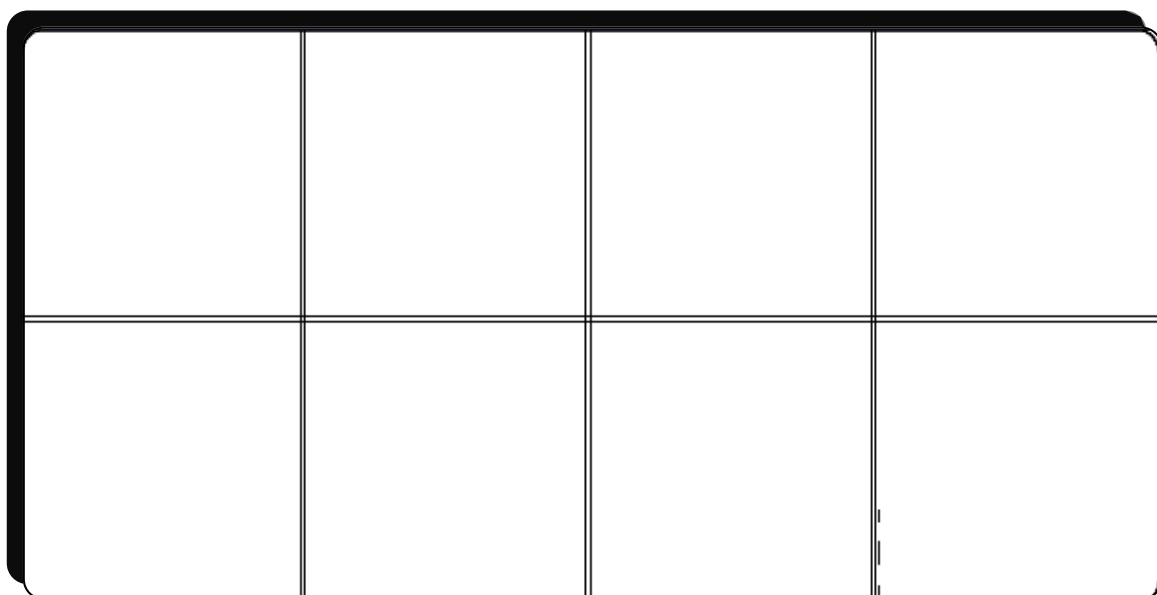

## Need Help?

With: Assembly Instructions  
Missing or damaged parts

**CALL: 0333 777 8999**

**IMPORTANT - RETAIN FOR FUTURE REFERENCE**

### BEFORE YOU START

#### Warnings

We suggest you retain these instructions for future reference

A wall strap is provided with your product, however you will need to source suitable fixings for your wall type. If in doubt, please consult a qualified trades person.

Always ensure the wall to be drilled is free from hidden electrical wires, water and gas pipes.

Avoid exposing the furniture to excessive heat or direct sunlight as this can cause damage to the materials and deterioration of the colour

#### Do's

We suggest you spend a short time reading through this leaflet before you start

When you are ready to start, make sure that you have the right tools and plenty of space

Unwrap all packaging materials and place the components on a clean surface to protect it from damage,

To clean your item, please use a vacuum or lightly brush clean

#### Number of people required to assemble

Two persons are required to assemble this item.

#### Time to assemble



30 minutes

#### Missing parts

If you are missing any fixtures and fittings for your product please contact our customer service team on 0333 777 8999 and they will be happy to arrange for a replacement to be sent to you free of charge.

#### Home service technicians

If you have a fault with your product please contact our customer service team on 0333 777 8999. If you have had the product for 28 days or less you may be offered a replacement, refund or for a fully trained home service technician to visit your home to assess the fault and repair the product where possible. If you have had the product for more than 28 days we will send an independant home service technician to review and repair the product where possible and recommend further action.

#### You can write to us at

Home Customer Services  
Next Retail Ltd,  
Desford Road,  
Leicester,  
LE19 4AT

**1**

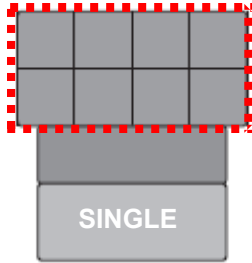

SINGLE

1 panel : Horizontal

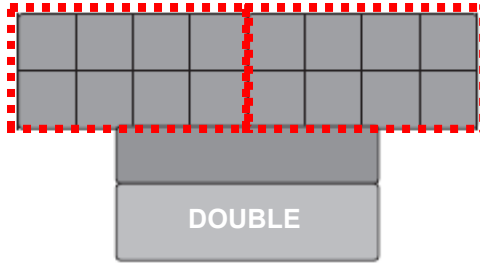

DOUBLE

2 panels : Horizontal

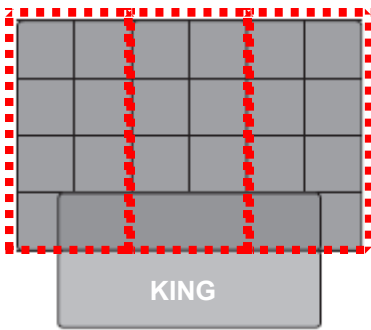

KING

3 panels : vertical

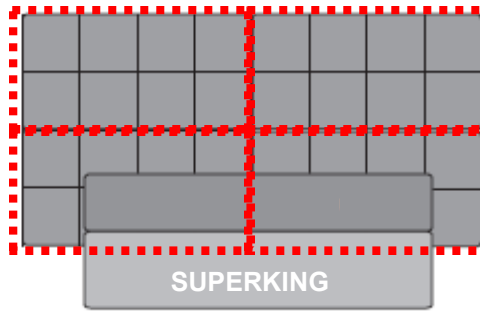

SUPERKING

4 panels : Horizontal



Centralise the Headboard / Headboards and mark their positions on the wall with a pencil.

Use a spirit level to ensure they are straight.

**2**

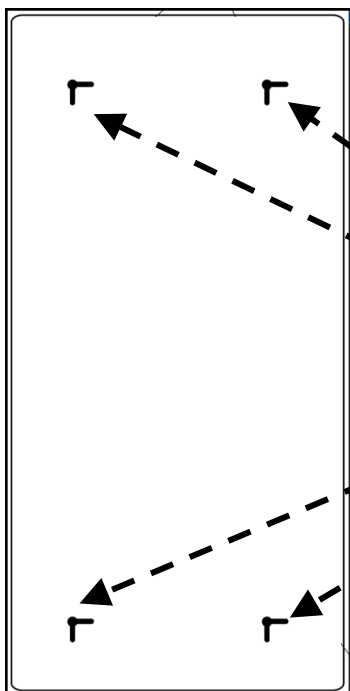

Cut away a small patch to reveal the hanging holes on the back of the headboard.

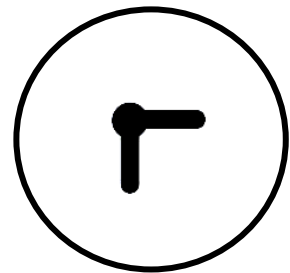
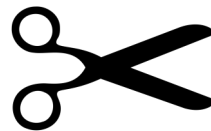

**3**

From your markings on the wall; Measure out the locations for the fixing holes as per the below diagram and mark these points on the wall with a pencil.

HORIZONTAL POSITION:

(Single / Double / Superking)

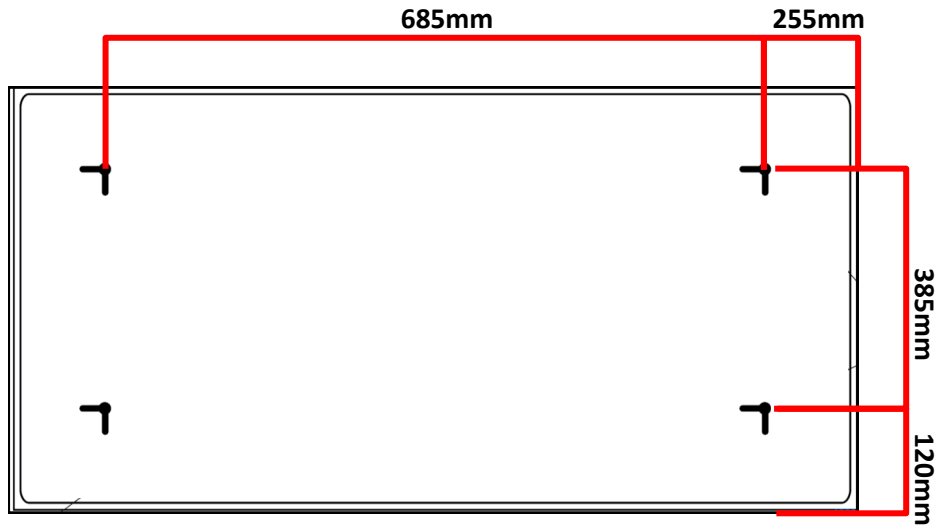

VERTICAL POSITION:

(King)

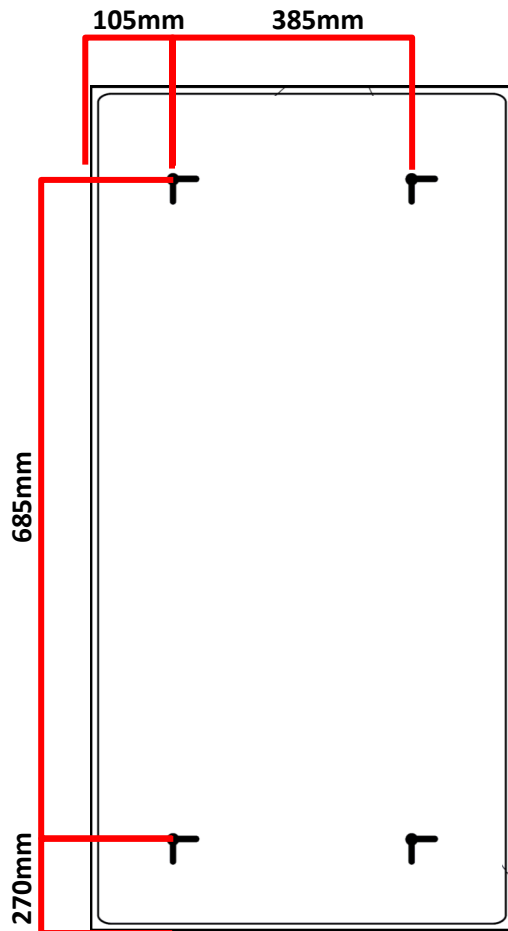

**4**

Wall fixings are not included please source suitable fixings for your wall type. If in doubt, please consult a qualified tradesperson. **WARNING:** Always ensure the wall to be drilled is free from hidden electrical wires, water and gas pipes.

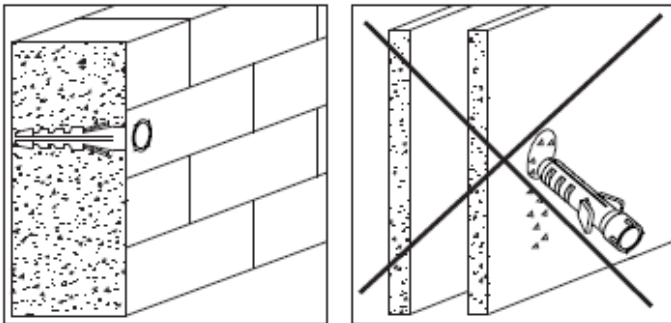

**X4 PER HEADBOARD**

**5**

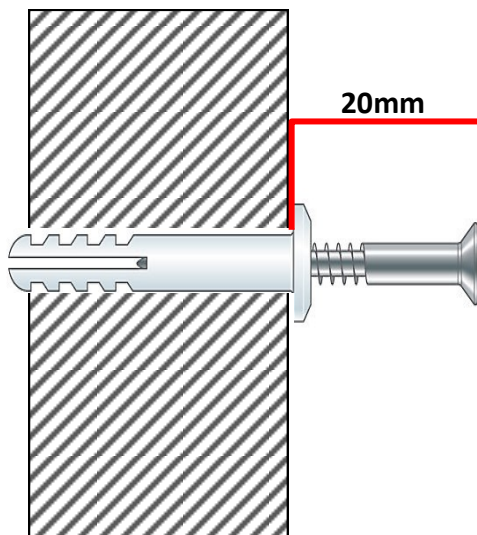

Leave 20mm of the screw from the wall to allow the fitting of the headboards.

6

Position the headboard over the fittings and attach by starting with lower end first then followed by the top end. Push the HB towards the wall, and once it is flush with the wall push the HB down about 15mm.

Make sure the HB is secure before use

**TIP:** If you're fitting more than one HB start with the lower one first

