

SPORT
YE-5920

361400

CROSS TRAINER

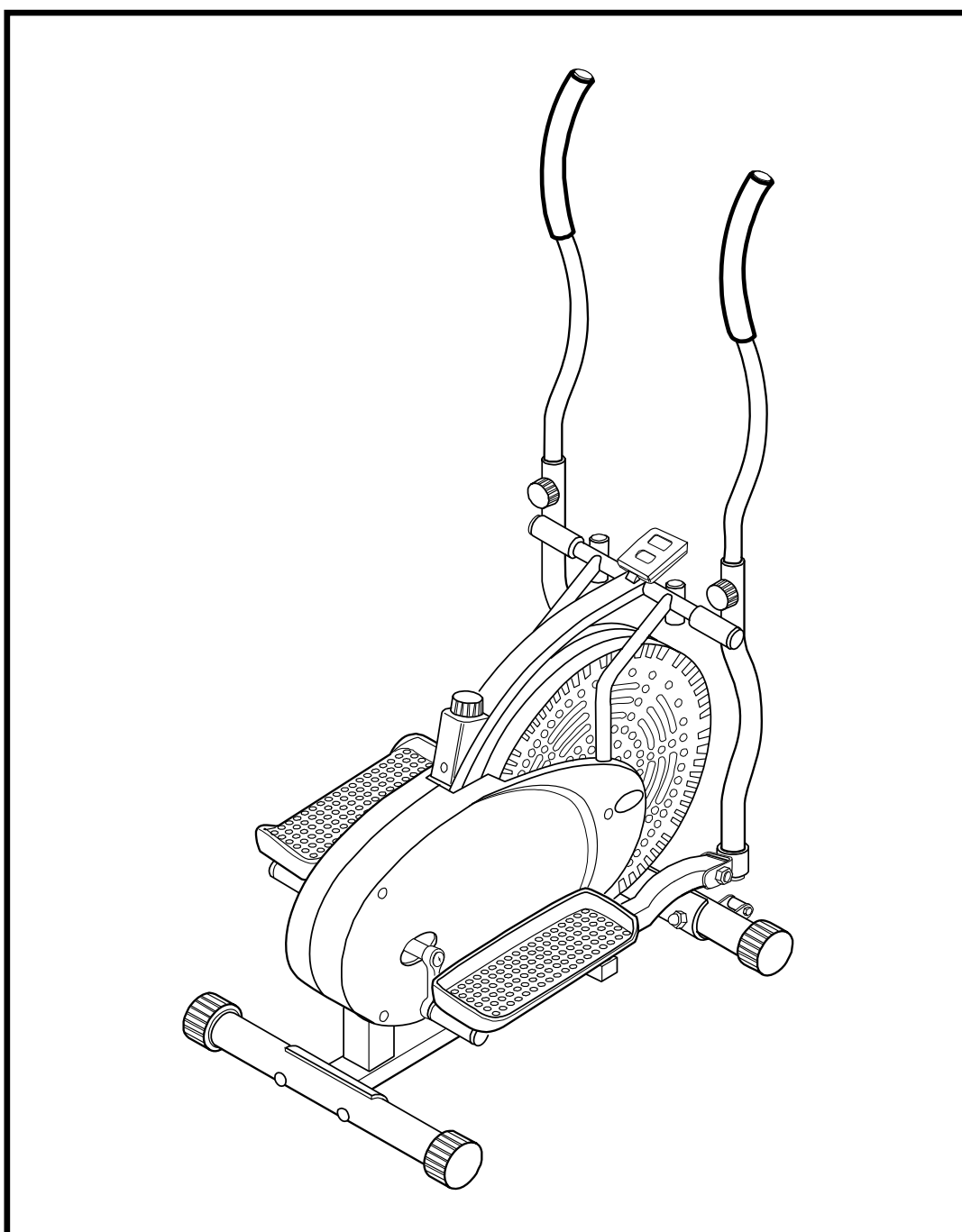

INDEX

<i>Important Safety Information</i>	1
<i>Exploded-View Assembly Drawing</i>	2
<i>Parts List</i>	3
<i>Assembly Instruction</i>	4
<i>Tension Adjustment</i>	6
<i>Exercise Instructions</i>	7
<i>Exercise Computer</i>	9
<i>Trouble Shooting</i>	9

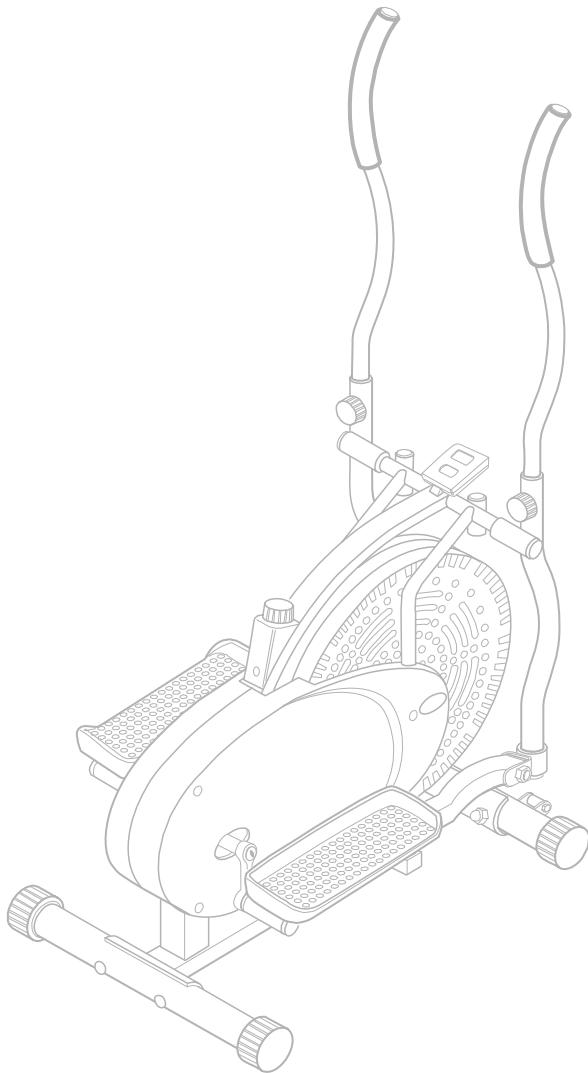

Important Safety Information

Please keep this manual in a safe place for reference.

1. It is important to read this entire manual before assembling and using the equipment.
Safe and effective use can only be achieved if the equipment is assembled, maintained and used properly. It is your responsibility to ensure that all users of the equipment are informed of all warnings and precautions.
2. Before starting any exercise program you should consult your doctor to determine if you have any medical or physical conditions that could put your health and safety at risk, or prevent you from using the equipment properly. Your doctor's advice is essential if you are taking medication that affects your heart rate, blood pressure or cholesterol level.
3. Be aware of your body's signals. Incorrect or excessive exercise can damage your health. Stop exercising if you experience any of the following symptoms: pain, tightness in your chest, irregular heartbeat, extreme shortness of breath, lightheadedness, dizziness, or feelings of nausea. If you do experience any of these conditions, you should consult your doctor before continuing with your exercise program.
4. Keep children and pets away from the equipment. The equipment is designed for adult use only.
5. Use the equipment on a solid, flat level surface with a protective cover for your floor or carpet. To ensure safety, the equipment should have at least 0.5 metres of free space all around it.
6. Before using the equipment, check that the nuts and bolts are securely tightened.
7. The safety of the equipment can only be maintained if it is regularly examined for damage and/or wear and tear.
8. Always use the equipment as indicated. If you find any defective components while assembling or checking the equipment, or if you hear any unusual noises coming from the equipment during use, stop immediately. Do not use the equipment until the problem has been rectified.
9. Wear suitable clothing while using the equipment. Avoid wearing loose clothing that may get caught in the equipment or that may restrict or prevent movement.
10. The equipment has been tested and certified to EN957 under class H.C.
Suitable for home use only. Maximum weight of user is 100kg. Braking ability is independent of speed.
11. The equipment is not suitable for therapeutic use.
12. Care must be taken when lifting or moving the equipment so as not to injure your back. Always use proper lifting techniques and/or seek assistance if necessary.
13. All moveable accessories (eg. pedal, handlebar, saddle....etc.) require weekly maintenance. Check them before use every time. If anything broken or loose, please fix them immediately. You may continue using bike after they return to good conditions

If you experience any problems or require assistance, please contact our customer services on 0844 800 8890

Monday-Thursday 08:00~16:30

Friday 08:00~15:30

or by mail support@hi-markgroup.co.uk

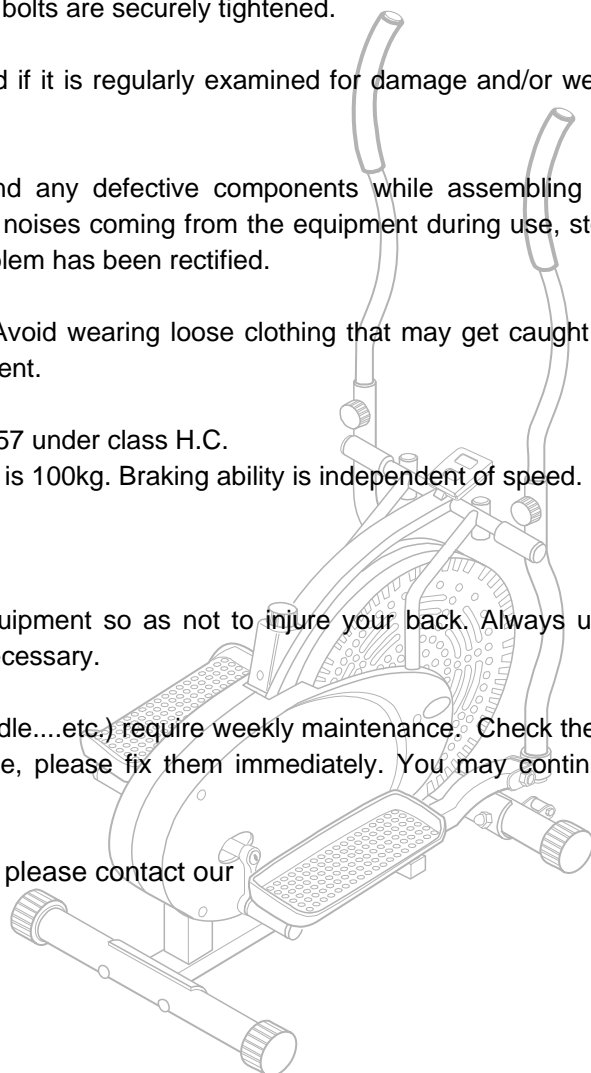

EXPLODED-VIEW ASSEMBLY DRAWING

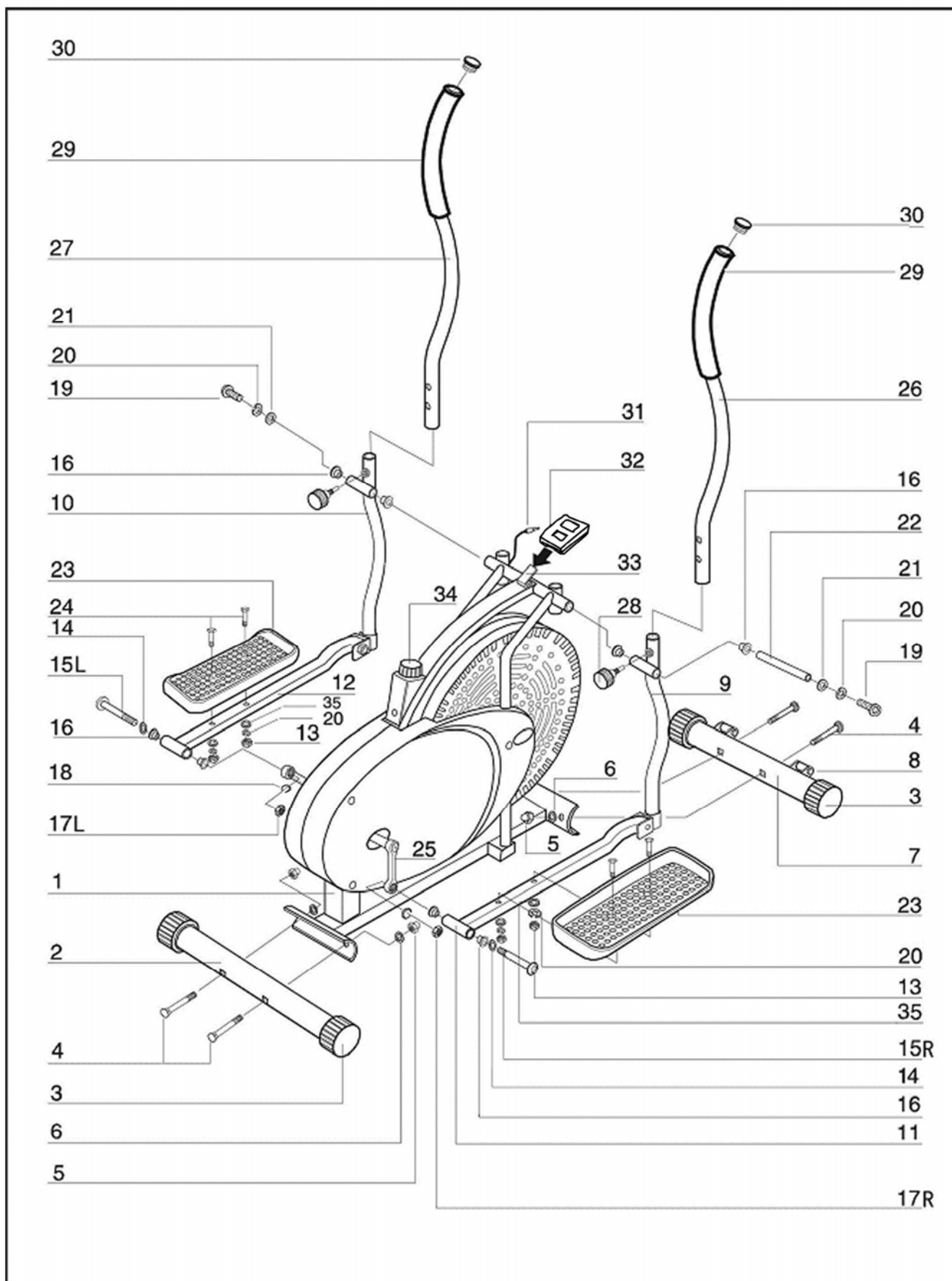

PART LIST

PART NO.	DESCRIPTION	QTY	PART NO.	DESCRIPTION	QTY
1.	Main Frame	1	19.	Hinge Screw	2
2.	Rear Stabilizer	1	20.	Spring Washer (Ø13xØ 8.5x Ø2.5)	6
3.	End Cap	4	21.	D Shape Washer (Ø28x5)	2
4.	Key head Bolt (3/8" x 2¼)	4	22.	Spindle bar	1
5.	Domed Nut (3/8")	4	23.	Pedal	2
6.	Curved Washer	4	24.	Bolt (3/8" x 2)	4
7.	Front Stabilizer	1	25.	Crank (Right & Left)	2
8.	Transportation Wheel	2	26.	Right Handlebar	1
9.	Lower Handle bar (Right)	1	27.	Left Handlebar	1
10.	Lower Handle bar (Left)	1	28.	Locking knob	2
11.	Right Pedal Post	1	29.	Foam Grip	2
12.	Left Pedal Post	1	30.	Handlebar Plug	2
13.	Nut (3/8")	4	31.	Computer Wire	1
14.	Undee washer	2	32.	Computer	1
15.	Pedal Hinge Bolt(Right &Left)	2	33.	Computer holder	1
16.	Steel Bushing (Ø5/8")	10	34.	Tension Control	1
17.	Nut (1/2") (Right & Left)	2	35.	Washer (3/8")	4
18.	Spring Washer	2			

Assembly & Usage

1. Tools you will need.

- * Ruler with both metric and English measurements
- * Adjustable wrench
- * Post Drive screwdriver

2. Review all safety guidelines in this manual.

3. Make sure you have the correct nuts and bolts etc, before beginning assembly.

N.B. nuts are measured by using the internal diameter.

For more information on parts, please see the exploded diagram and parts list.

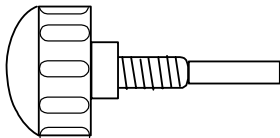

No.28 Locking Knob

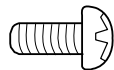

No.19 Hinge Screw

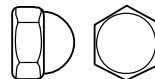

No.5 Domed Nut (3/8")

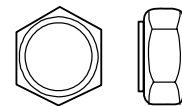

No.17 Nut (1/2")

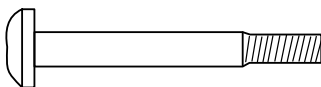

No.15 Pedal Hinge Bolt

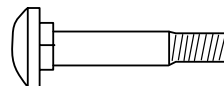

No.4 Key head Bolt (3/8"x21/4")

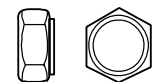

No.13 Nut (3/8")

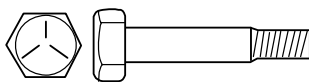

No.24 Bolt (3/8"x2)



No.18 Spring Washer

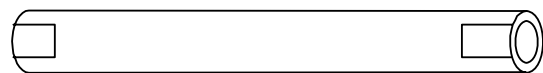

No.22 Spindle Bar

ASSEMBLY INSTRUCTIONS

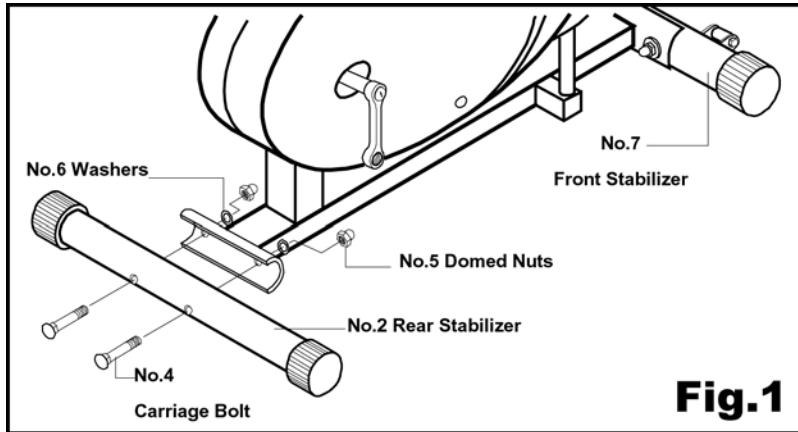

STEP 1

Attached the Front and Rear Stabilizers (pt.7 & pt.2) with Four Carriage Bolts (pts.4), Washers (pts.6) and Domed Nuts (pts.5).

N.B. the Front Stabilizer has the integral transport wheels.

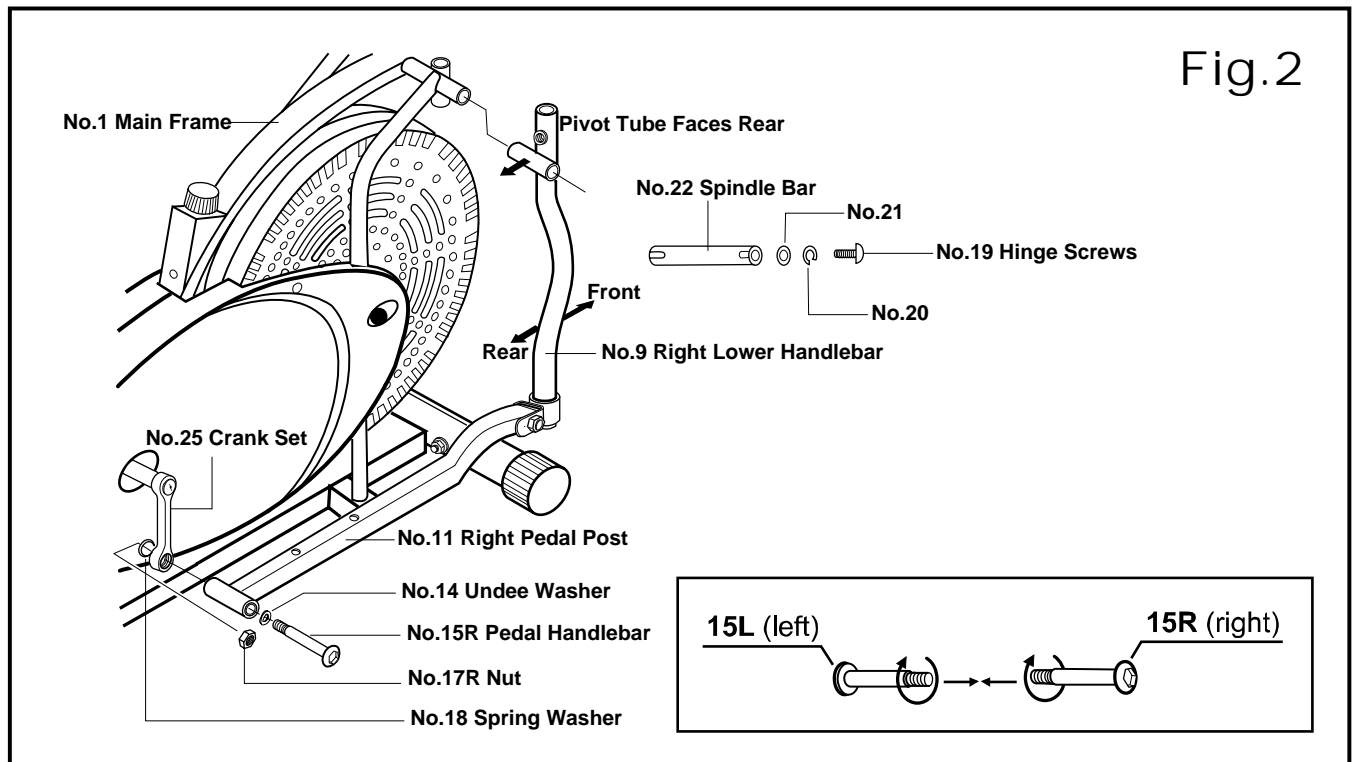

STEP 2

Insert the Spindle Bar (pt.22) through the Right Lower Handlebar (Pt.9) and through the main frame, and then, through the Left Handlebar (Pt.10). Put a D shape washer and a Spring Washer (Pts.20 & 21) on either side of the spindle bar and tighten up both ends using the Hinge Screws (Pt.19)

Then insert a Pedal Hinge Bolt (Pt.15R) and a Undee Washer (Pt.14) through the Pedal Post (Pt.11 for the right side, Pt.12 for the left), put a Spring Washer (Pt.18) on the bolt, then pass it through the Crank (Pt.25), and secure the bolt with an M12 Nut (Pt.17R). Repeat this procedure for the left side.

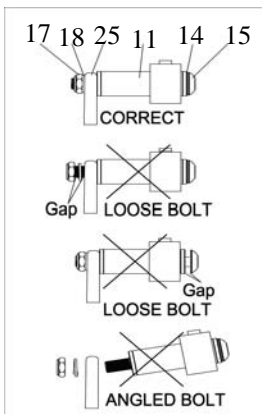

ATTENTION:

The Right and Left Bolt (15R&15L) must fully penetrate the nylon ring inside the connecting Tube (11&12) and the Right and Left Crank (25). This will ensure the stability and durability of you AERO ELLIPTICAL STRIDER.

In order to install each hinge bolt properly, keep it straight as the Hinge Bolt goes through the connecting Tube and the Crank. If the Hinge Bolt is connected to the crank at an angle, damage to both the Hinge Bolt and the Crank may occur.

CAUTION: MAKE SURE ALL THE BOLTS AND NUTS ARE SCREWED TIGHT PRIOR TO WORKOUT.

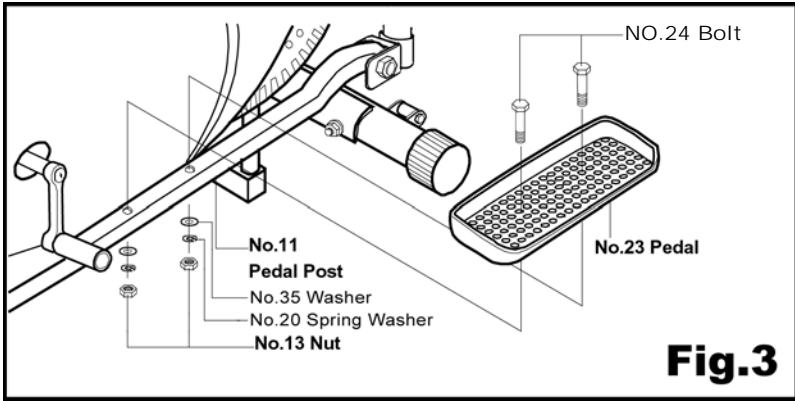

STEP 3

Attach the pedals (pt.23) to the Pedal Posts (pt.11 & pt.12), using two 3/8" x 2" Bolts (pt.24), two 3/8" Washer (Pt.35), two ϕ 13X ϕ 8.5X2.5 spring Washer (Pt.20) and two 3/8" nuts (pts.13) for each side. See **Fig.3**.

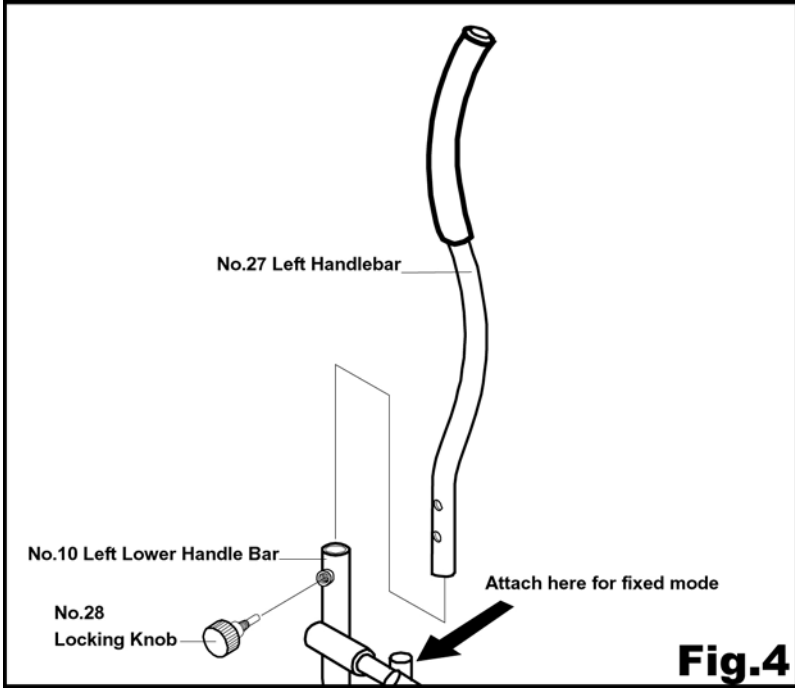

STEP 4

When fixing your handlebars (pt.26 & pt.27), you can either have the dual-action mode or the fixed mode.

Dual-action mode: To allow the handlebars to move along with the pedals, attach them to the lower handle bars .Select a height setting that is comfortable to you and make sure both handlebars are set at the same height. Lock each handle bar in place with the locking knobs(pts.28). See **Fig.4**.

Fixed mode: To keep the handlebars stationary, attach them to the tubing on the main frame between the lower handlebars.

As with the dual-action mode, set both handlebars at the same comfortable height and secure them in place with the locking knobs (pts.28).

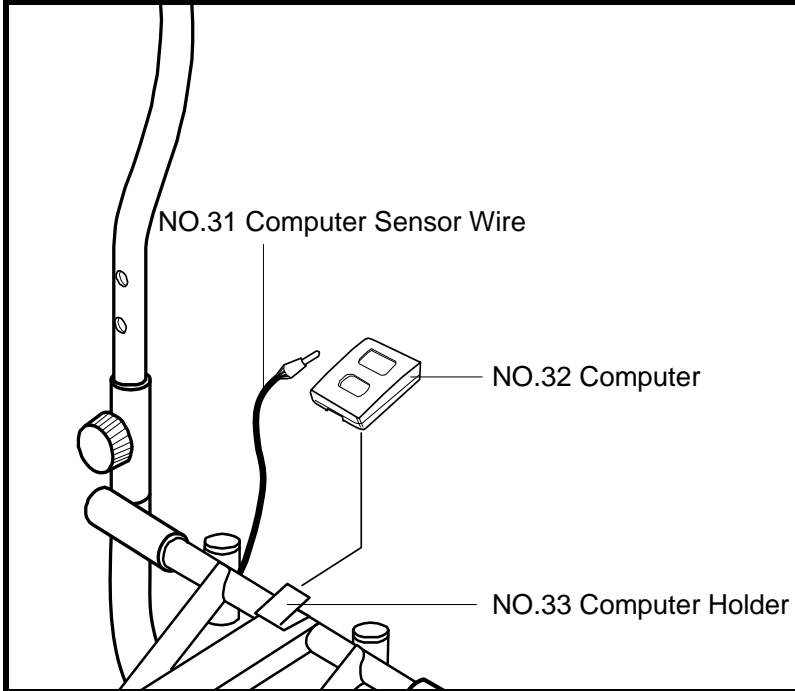

STEP 5

Slide the computer (pt.32) onto the computer holder (pt.33), then insert the computer wire (pt. 31) into the computer (pt.32). See **Fig.5**.

Tension Adjustment

The assembly of your cross trainer is now complete. When you try it for the first time, you should adjust the tension to the correct level before you begin a full workout.

For minute tension adjustment, simply use the tension adjustment knob (pt.34) found at the top center. The tension level can be changed, using this adjustment knob to vary intensity of workout as you exercise.

For greater tension adjustment, you may loosen or tighten the friction belt by re-strapping it. To do so, first turn the tension adjustment knob to the loosest setting. Then re-strap the belt at the buckle on the top of the fan wheel just beneath the center beam. The more length you allow on the friction belt the less friction it will cause (less tension). Re-adjust the tension knob after you finished re-strapping.

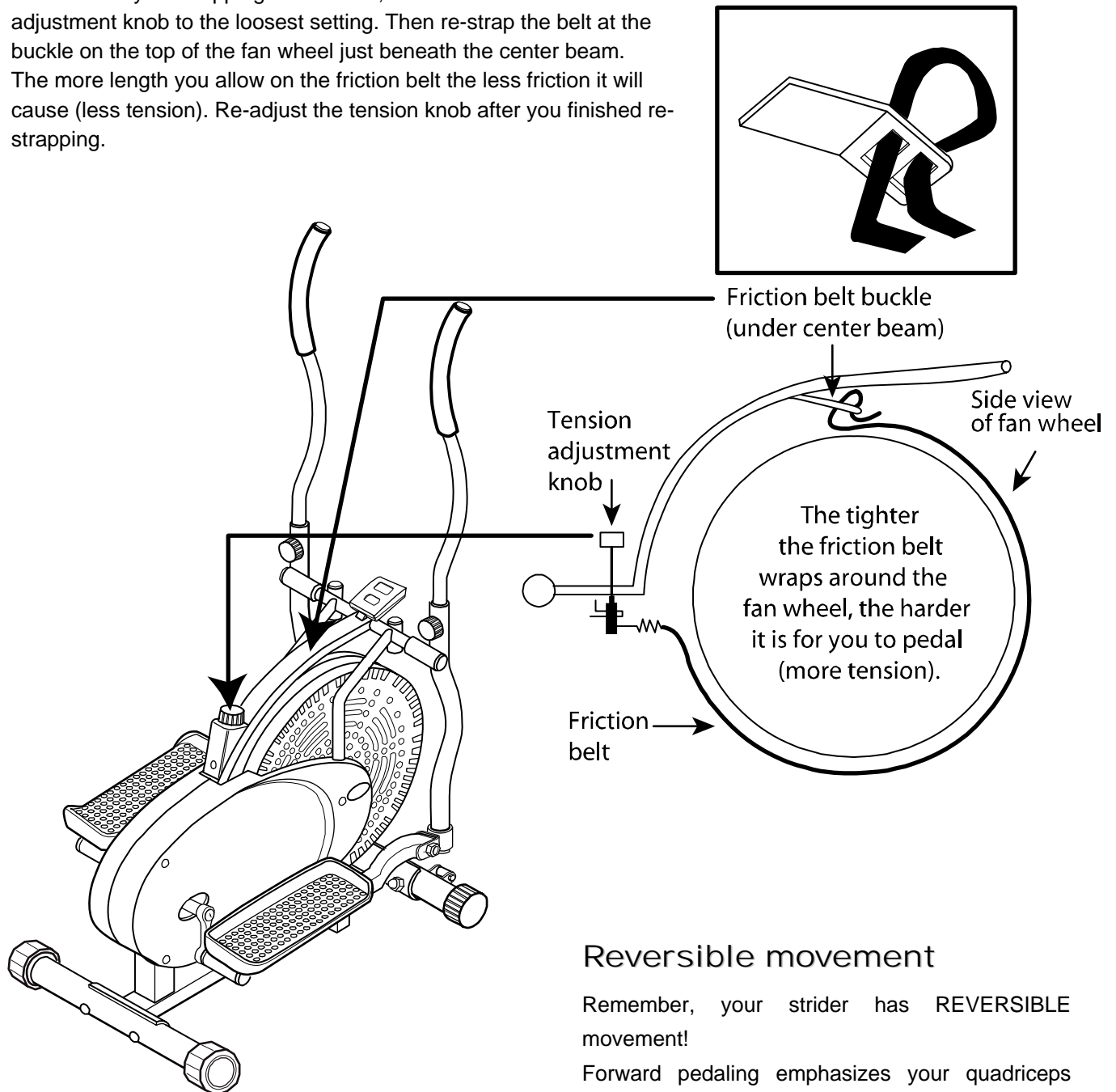

Reversible movement

Remember, your strider has REVERSIBLE movement!

Forward pedaling emphasizes your quadriceps muscles (front thighs), while backward pedaling emphasizes your hamstrings (back thighs).

Take advantage of this fact to make your workout less fatiguing, and more fun.

EXERCISE INSTRUCTIONS

Using your **CROSS TRAINER** will provide you with several benefits. It will improve your physical fitness, tone your muscles and, in conjunction with a calorie-controlled diet, help you lose weight.

1.The Warm-Up Phase

This stage helps get the blood flowing around the body and the muscles working properly. It will also reduce the risk of cramp and muscle injury. It is advisable to do a few stretching exercises as shown below. Each stretch should be held for approximately 30 seconds. Do not force or jerk your muscles into a stretch - if it hurts, **STOP**.

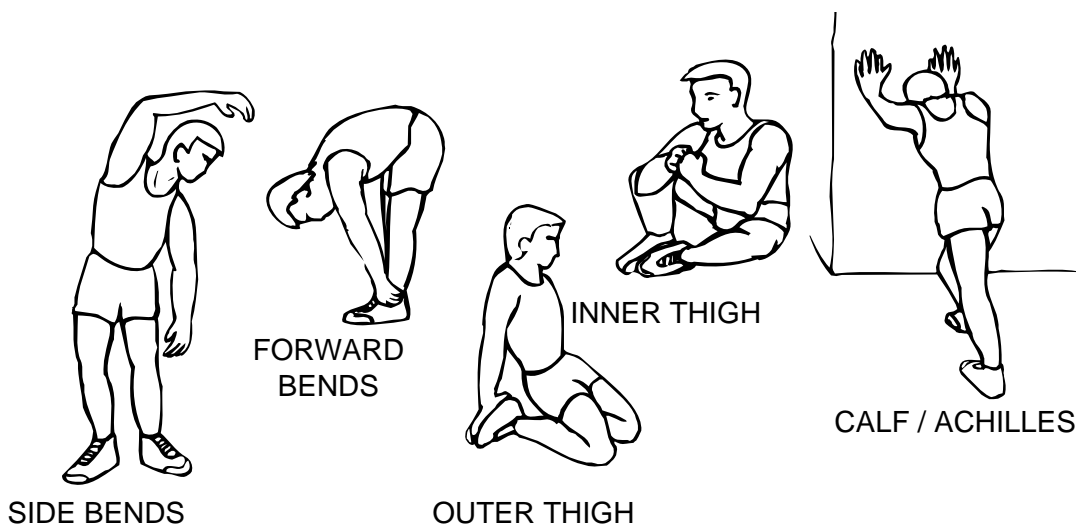

2.The Exercise Phase

This is the stage where you put the effort in. After regular use, the muscles in your legs will become more flexible. Work at your own pace, but be sure to maintain a steady tempo throughout. The rate of work should be sufficient to raise your heartbeat into the target zone shown on the graph below.

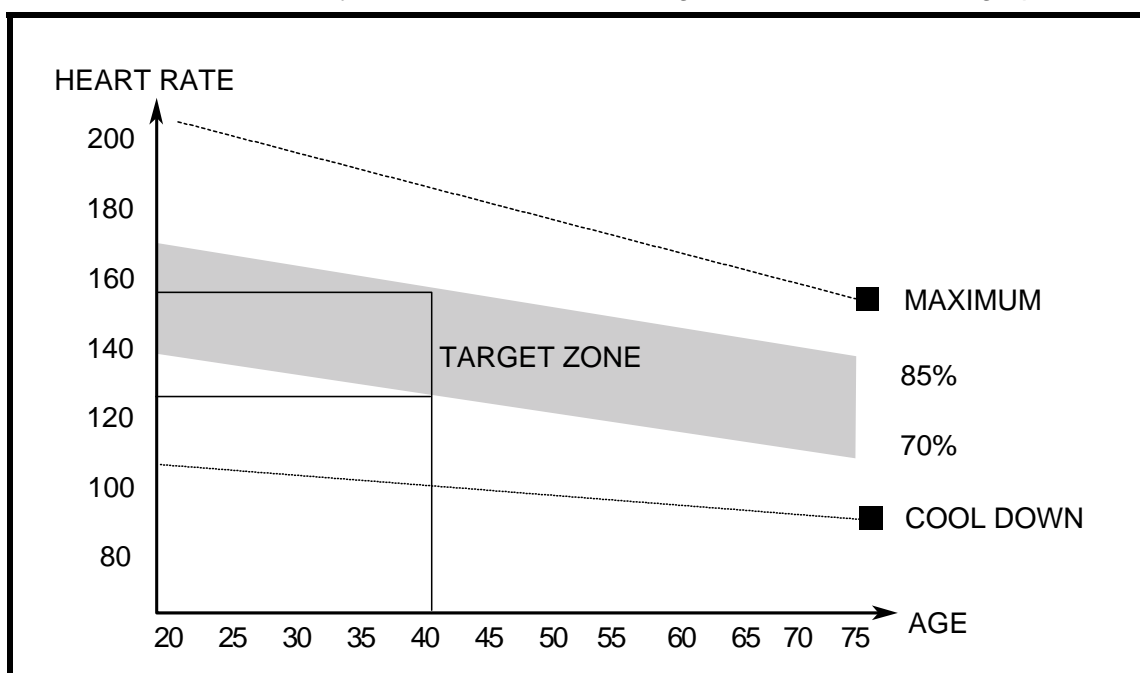

This stage should last for a minimum of 12 minutes though most people start at about 15-20 minutes

3. The Cool-Down Phase

This stage is to let your Cardio-vascular System and muscles wind down. This is a repeat of the warm up exercise e.g. reduce your tempo, continue for approximately 5 minutes. The stretching exercises should now be repeated, again remembering not to force or jerk your muscles into the stretch.

As you get fitter you may need to train longer and harder. It is advisable to train at least three times a week, and if possible to space your workouts evenly throughout the week.

MUSCLE TONING

To tone muscle while on your **cross trainer** you will need to have the resistance set quite high. This will put more strain on your leg muscles and may mean you cannot train for as long as you would like. If you are also trying to improve your fitness you may need to alter your training program. You should train as normal during the warm-up and cool-down phases, but towards the end of the exercise phase you should increase the resistance by making your legs work harder than normal. You will have to reduce your speed to keep your heart rate in the target zone.

WEIGHT LOSS

The important factor here is the amount of effort you put in. The harder and longer you work the more calories you will burn. This is effectively the same as if you were training to improve your fitness, the difference being the goal.

EXERCISE COMPUTER

FUNCTION BUTTON

MODE PRESS TO SELECT FUNCTION DISPLAY, AND HOLD ON PRESSING FOR 4 SECONDS TO HAVE ALL FUNCTION VALUES TOTAL RESET.
(THERE IS NO SINGLE FUNCTION RESET AVAILABLE.)



FUNCTIONS

- SCAN** AUTOMATICALLY SCANS THROUGH EACH FUNCTION EVERY 6 SECONDS.
- TIME** DISPLAYS THE ACCUMULATED TIME UP TO 99:59 DURING EXERCISING..
- SPEED** DISPLAYS THE CURRENT SPEED UP TO 999.9KM/H OR ML/H, THE VALUE.
- DISTANCE** DISPLAYS THE ACCUMULATED DISTANCE UP TO 99.99 KM OR ML DURING.
- CALORIES** DISPLAYS THE ACCUMULATED CALORIE CONSUMPTION UP TO 999.9 CAL DURING EXERCISING.

(THIS DATA IS A ROUGH GUIDE FOR COMPARISON OF DIFFERENT SESSIONS EXERCISING SESSIONS THAT CAN NOT BE USED FOR MEDICAL TREATMENT.)

NOTE

1. WHEN STOP EXERCISING, THERE WILL BE A STOP SIGN SHOWN ON THE UPPER-LEFT CORNER.
2. WITH NO SIGNAL TRANSMITTED INTO THE MONITOR IN A PERIOD OF 4 MINUTES, THE LCD DISPLAY WILL SHUT OFF AUTOMATICALLY, AND ALL FUNCTION VALUES WILL BE STORED
3. TURN ON THE MONITOR BY PRESSING THE BUTTON OR START EXERCISING, ALL FUNCTION VALUES(SPEED EXCLUDED) WILL START COUNTING FROM PREVIOUS DATAS.
4. IF IMPROPER DISPLAY ON MONITOR, PLS RE-INSTALL THE BATTERIES TO HAVE A GOOD RESULT.

TROUBLE SHOOTING.

1. **Change the battery.** To change the computer battery, please slide the computer from the computer holder, remove the battery cover on the back of the computer console, and remove the batteries. Replace with 2 x AA batteries. Finally put the cover back on the console, and slide the computer back on the computer holder.
2. **Computer not working correctly.** If your computer is not working correctly, please check whether the lower sensor wire is connected to the upper sensor wire, and make sure the upper sensor wire is plugged into the computer. When you have checked the above, and the computer still not working, then please make sure the batteries are installed correctly in the computer and that the batteries are still working.
3. **No resistance.** If there is no tension resistance on the bike, please make sure the upper tension cable is connected to the lower tension cable. Turn the tension knob anti-clockwise to it's lowest level, then go to the tension strap buckle which is situated on top of the flywheel cover at the base of the front post. Loosen the tension strap, pull it through the buckle until you can feel some resistance on the strap then lock it back around the buckle. Now mount the cycle and turn the pedals, the tension control knob can now be used for a finer adjustment. If you find it is now too tight go back to the tension strap buckle and loosen the strap slightly.

MAINTENANCE

1. Before using the cross trainer, always make sure all bolts/nuts are fully tightened.
2. A spent battery is hazardous waste, please dispose of it correctly, and do not throw it in the trash.
3. When eventually you want to scrap the machine, you should remove the batteries from the computer, and dispose separately as hazardous waste.

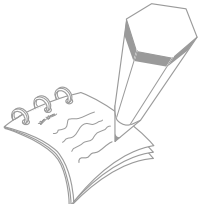

EXERCISE NOTES

Use this space to record your own exercise routine results

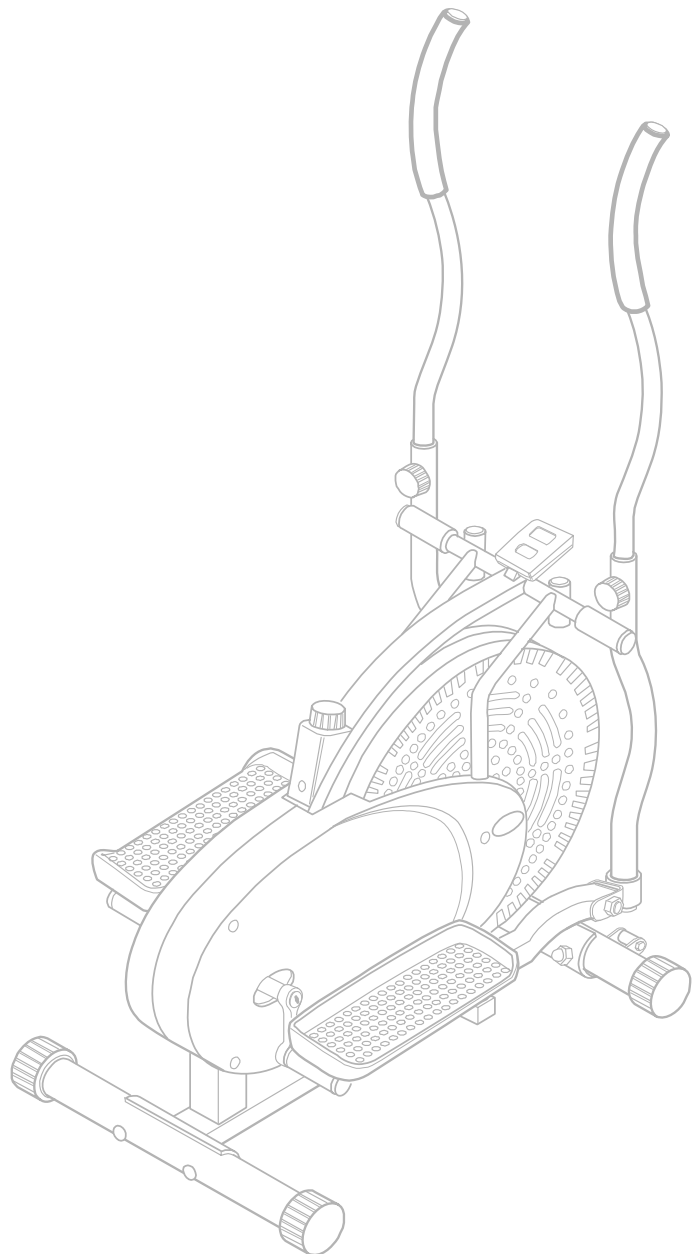

WASTE ELECTRICAL AND ELECTRONIC EQUIPMENT

The Waste Electrical and Electronic Equipment Regulations 2006 (the WEEE Regulations) came into effect in the United Kingdom on 1st July 2007. The Regulations have been designed to prevent/reduce the amount of waste electrical and electronic equipment by promoting its reuse, recycling and recovery. The separate collection of WEEE saves energy and resources and avoids hazardous materials from going to landfill.

Electrical and electronic equipment is any product that relies on electricity or batteries to perform its primary function, for example a kettle or a watch.

Products which are covered by the WEEE Regulations have a crossed out wheelie bin symbol on either the product itself or its packaging.

This symbol aims to encourage you to identify and dispose of WEEE product separately from other household waste when it reaches the end of its life.

From 1st July 2007, Next is required to offer a free method of disposal of your old electrical and electronic equipment. Next has joined a UK wide distributor take back scheme (DTS) to assist in delivering UK wide WEEE collection system to encourage our customers to recycle these goods. Next has contributed towards the development of WEEE collection facilities, known as Designated Collection Facilities (DCF), for consumers to use throughout the UK.

If you have an old electrical or electronic product that has reached the end of its life you can deposit it free of charge for segregation and recycling at Civil Amenity Sites which are registered as DCF.

To find your nearest WEEE collection point visit

www.recycle-more.co.uk.

Please have your postcode ready to type in the recycling bank locator.

You can also call the recycle-more helpline on **08450 682572**



Next Retail Ltd





GUARANTEE

This product is guaranteed for 1 year from the date of purchase. If any defect arises due to faulty materials or workmanship, the unit will either be repaired, replaced or refunded at our discretion.

The following conditions apply

- The product must be returned to Next with original proof of purchase.
- The products must be installed and used in accordance with the instructions counterstained in the instruction guide.
- It must be used only for domestic purposes.
- It does not cover wear & tear, damage, misuse or consumable parts.
- We accept no responsibility for incidental or consequential loss or damage.
- Valid in the UK only.

Next Retail Ltd
Desford Road, Enderby
Leicester LE19 4AT
www.next.co.uk
www.nextelectric.co.uk

*If you experience any problems or require assistance,
please contact our
customer services on 0844 800 8890*

Monday-Thursday 08:00~16:30

Friday 08:00~15:30

or by mail support@hi-markgroup.co.uk



** This service is available for UK residents only.*

