

BEFORE YOU GET STARTED...

We're confident you'll love your gorgeous new Next furniture. However, it's worth making absolutely certain before you put it all together.

So, let's quickly run through these three steps:

1. COLOUR

Make sure you're happy with the colour
No need to unpack everything, just check the first component.

2. PROTECTIVE PACKAGING

If you're happy, then it's time to get opening! Start by laying everything out on the protective packaging – this will prevent anything getting scratched.

3. PARTS PAGE

Finally, double check you have all the pieces by referencing the parts page of the instructions.

TIPS FOR RETURNS

Not completely happy with the product? No problem. We just need everything back in the original packaging, so follow the steps below and this will ensure a super-smooth returns process and no delay to your refund.

DO



- Check everything is there (the 'parts page' is a handy checklist).
- Pop all the loose fittings and fixtures into the packaging provided or tie them up in a plastic bag.
- Wrap all the big components back up in the original protective packaging.
- Close up the box and seal it securely (don't be afraid to use plenty of tape).

DON'T



- Leave anything assembled - all components should be dismantled and separately packed.
- Put loose fixtures and fittings straight into the box.
- Throw it back in the box carelessly - as it may get damaged.

next
HOME

Then just give us a call on 0333 777 8999 and we'll sort out a pick up time for you.

next

HAMPTON GENTS WARDROBE

Assembly Instructions

Actual product size

H203.5 x W120 x D62 cm



STONE

MINK

CHALK

IVORY

MIST

SAGE

PEWTER

Need Help?

With: Assembly instructions
Missing or damaged parts

CALL: 0333 777 8999

IMPORTANT- RETAIN FOR FUTURE REFERENCE

Assembly Instructions

BEFORE YOU START

Warnings

We suggest you retain these instructions for future reference.

Keep fittings out of children's reach and keep children well away from the construction area.

This product should only be used on firm, level ground.

Please periodically check all fitting and re-tighten as necessary

Please do not sit or stand on your furniture.

Avoid exposing the furniture to excessive heat or direct sunlight as this can cause deterioration of the colour.

Unwrap all packaging materials and place the components on top of the carton box or on a clean floor to protect it from damage.

Do's

We suggest you spend a short time reading through this leaflet before you start.

When you are ready to start, make sure that you have the right tools and plenty of space.

Unwrap all packaging materials and place the components on a clean surface to protect it from damage.

We recommend that the packaging is used to protect the surfaces during assembly.

Carefully check that you have all the parts before beginning assembly

Due to the size of the product we recommend that it is assembled in the room intended for use.

Ensure the product is fully assembled as illustrated and all fixings are fully tightened before use.

Wipe occasionally with a soft cloth slightly dampened with water. Then buff with a dry clean soft cloth.

Wood will mellow and change colour over time, we recommend that ornaments and items placed on the surface are moved regularly for the first few months to prevent uneven mellowing

Don'ts

Do not drag or pull your furniture.

Do not use silicone based furniture polish. Silicone in furniture polishes can break down the finish.

Never allow any kind of liquid to remain on your furniture.

Absorption can cause wood to warp or finishes to de-laminate.

Do not place hot items (e.g. hot drinks) directly on to the wood surface. Please make sure you use a placement or coaster.

Number of people required to assemble

Two persons are required to assemble this item.

Time to Assemble



1 hour

Tools required

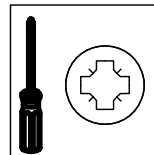

not supplied

Tipping Kit supplied

Missing parts

If you are missing any fixtures and fittings for your product please contact our customer service team on 0333 777 8999 and they will be happy to arrange for a replacement to be sent to you free of charge.

Home service technicians

If you have a fault with your product please contact our customer service team on 0333 777 8999. If you have had the product for 28 days or less you may be offered a replacement, refund or for a fully trained home service technician to visit your home to assess the fault and repair the product where possible. If you have had the product for more than 28 days we will send an independant home service technician to review and repair the product where possible and recommend further action.

You can write to us at

Home Customer Services
Next Retail Ltd,
Desford Road,
Leicester,
LE19 4AT

To View our full furniture range please visit www.next.co.uk

GETTING TO KNOW YOUR PRODUCT

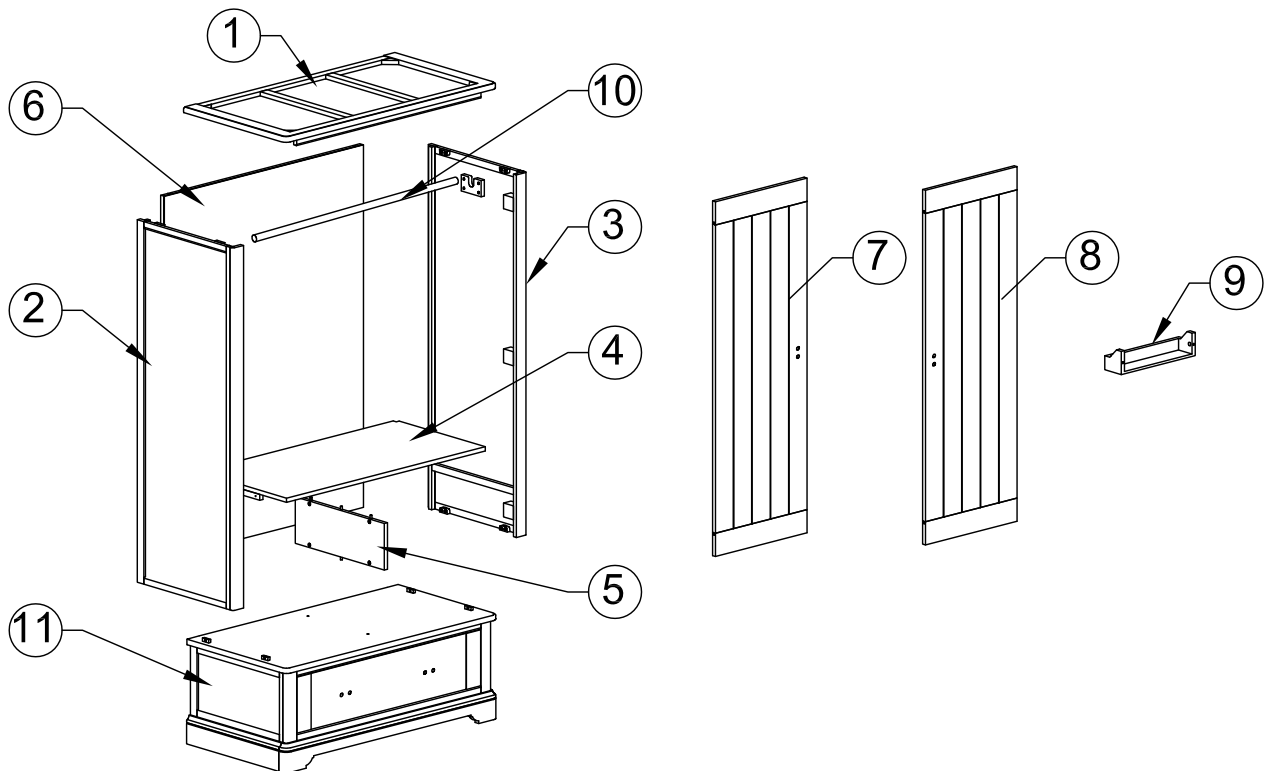

Components supplied. Please use this guide if you require replacement parts

Ref	Dimensions	Visual	Qty	ctn
1	120 x 62 cm		1	1
2	156 x 58 cm		1	1
3	156 x 58 cm		1	1
4	112 x 53 cm		1	1
5	53 x 20 cm		1	1
6	156 x 112.5cm		1	1

Ref	Dimensions	Visual	Qty	ctn
7	138.6 x 51.7 cm		1	1
8	138.6 x 51.7 cm		1	1
9	41.7 x 10 cm		1	1
10	111.6 x 3 cm		1	1
11	120 x 60 cm	 Remove polystyrene block	1	2

Assembly Instructions

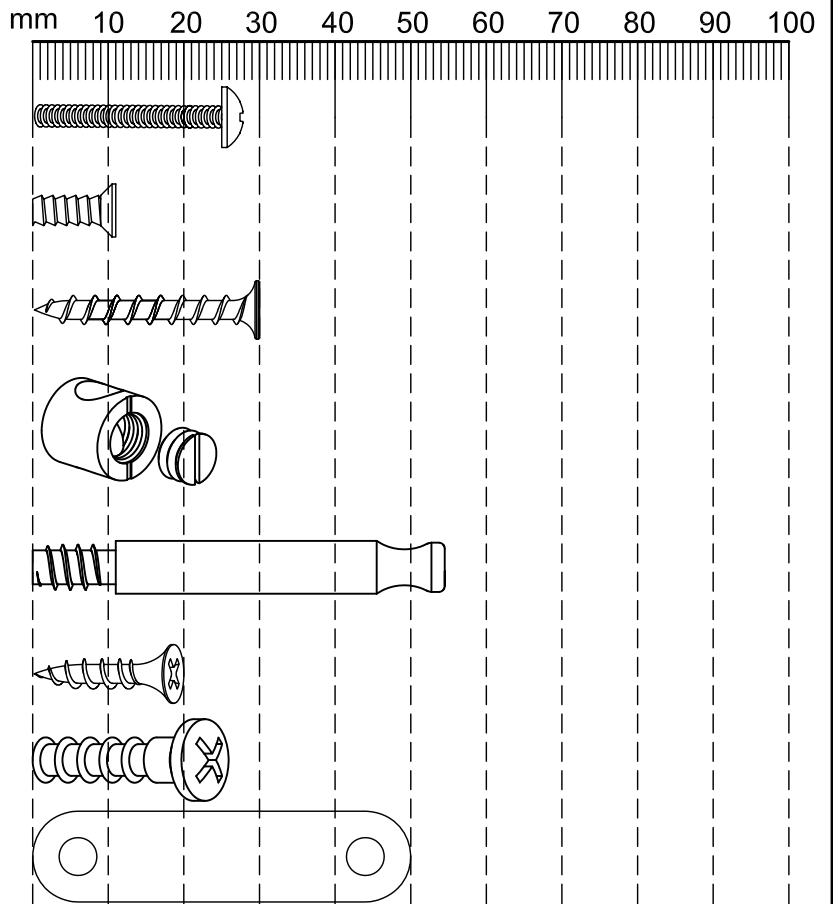

Fixtures and fitting supplied (actual size)

Ref	Dimensions	Quantity	* Extra Fitting
A	4 x 25 mm	4	1
B	4 x 11 mm	12	0
C	4 x 30 mm	14	2
D	15 x 13 mm	6	1
E	6 x 44 mm	6	1
F	4 x 20 mm	8	1
G	5 x 19 mm	8	1
H	15 x 50 mm	2	1



Remove polystyrene block from behind drawer in base

Fixtures and fitting supplied (not to sscale)

Ref	Dimensions	Visual	Qty
I	N/A		2
J	N/A		2

Assembly Instructions

1

7

8

12

H2 x 6 N/A

2

11

E

E x 2 6 x 54mm

Remove handle from inside box

Attach handle to the front drawer

CAM BOLT
tighten until shoulder is flush with panel. Do not overtighten or undertighten (see example below)

Shoulder

NO GAP

Assembly Instructions

3

C x 5 4 x 30mm	D x 2 15 x 13mm	G x 2 5 x 19mm
-------------------	--------------------	-------------------

4

C x 5 4 x 30mm	G x 2 5 x 19mm
-------------------	-------------------

5

C x 4 4 x 30mm	D x 2 15 x 13mm	E x 2 6 x 54mm
-------------------	--------------------	-------------------

Assembly Instructions

6

7

B x 12 4 x 11mm

F x 4 4 x 15mm

H x 2 15 x 50mm

8

9

A x 4 4 x 25mm

I x 2 N/A

F x 4 4 x 20mm

L x 2 N/A

Assembly Instructions

10

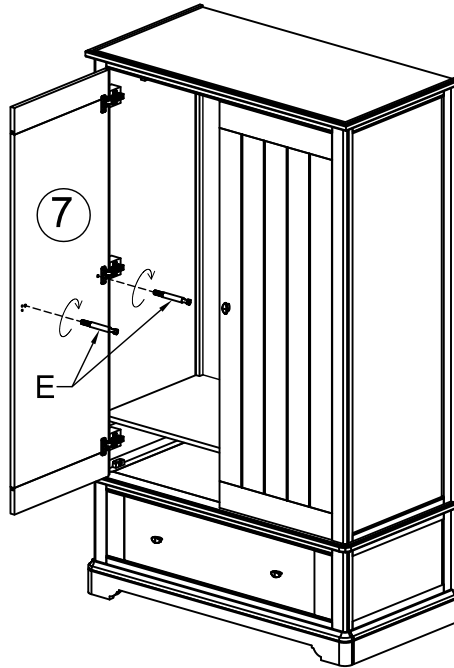

CAM BOLT
tighten until shoulder is flush
with panel. Do not overtighten
or undertighten (see example
below)

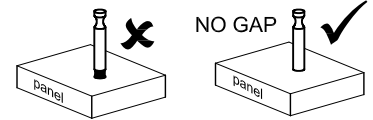
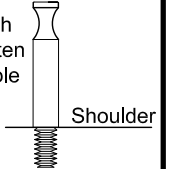

E x 2 6 x 54mm

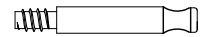

11

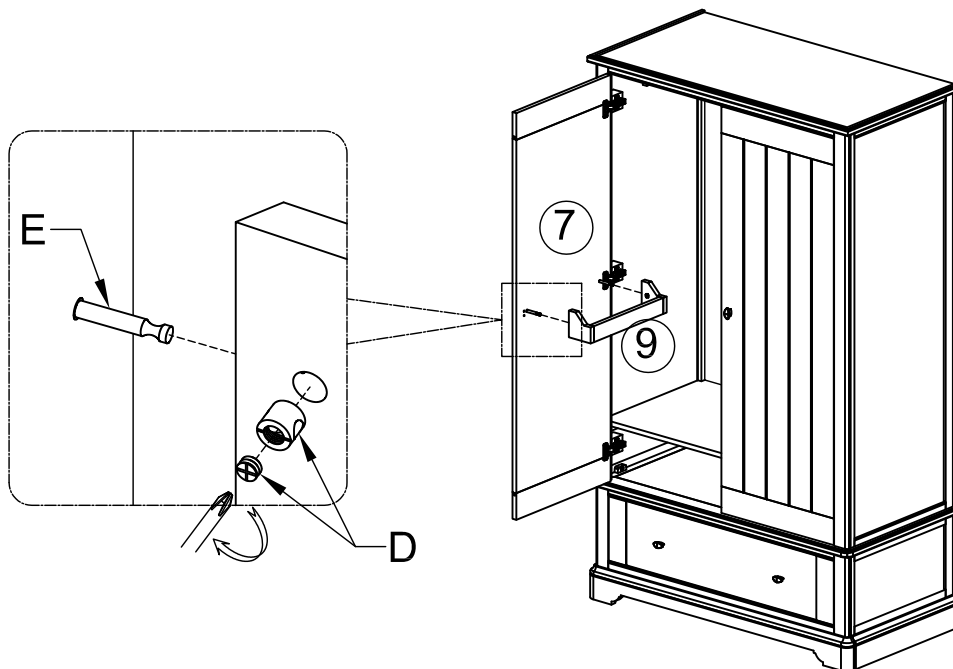

D x 2 15 x 13mm



Assembly Instructions

Adjust once door is open to even up gaps

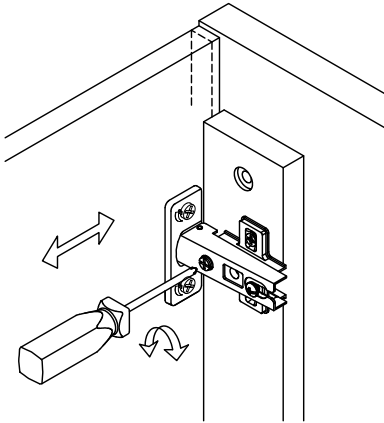

Turn outer screw to move door left or right

Turn screw fully anti-clockwise on each hinge before attempting to fit the door

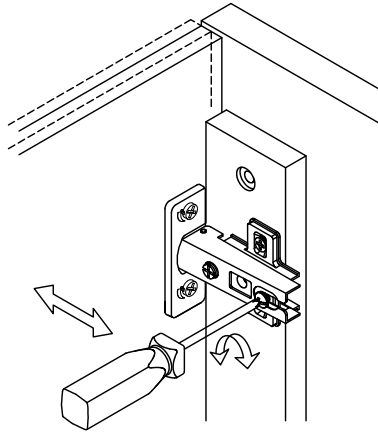

Turn Inner screw to move door in or out

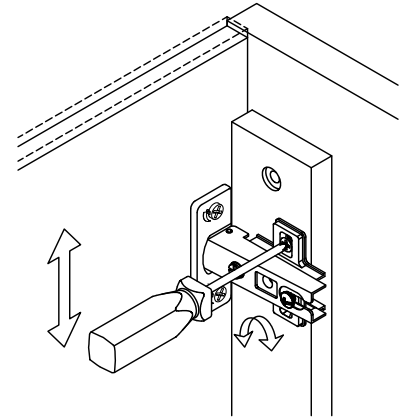

Turn top screw to move door up or down

Fit the hinge plates to the side but do not tighten the screws until you have positioned the door vertically in its correct position.

ASSEMBLY

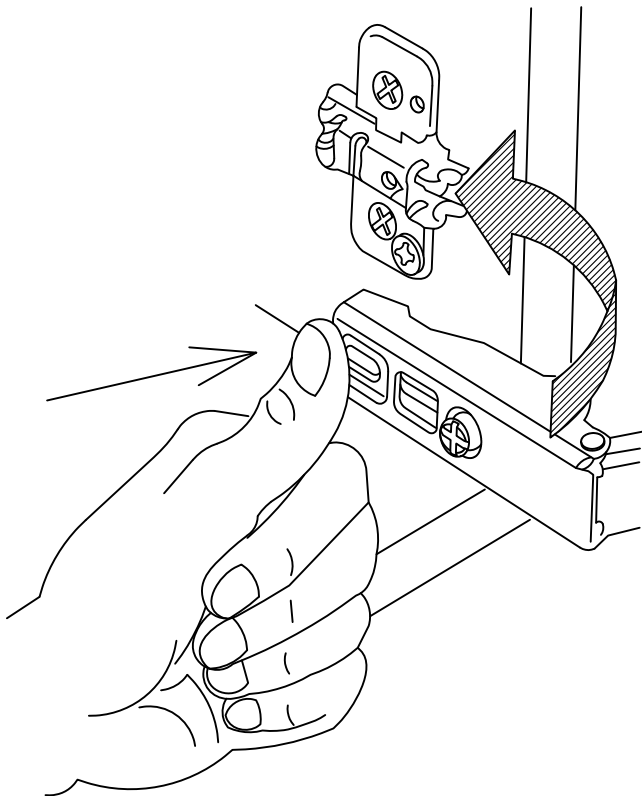

DISASSEMBLY

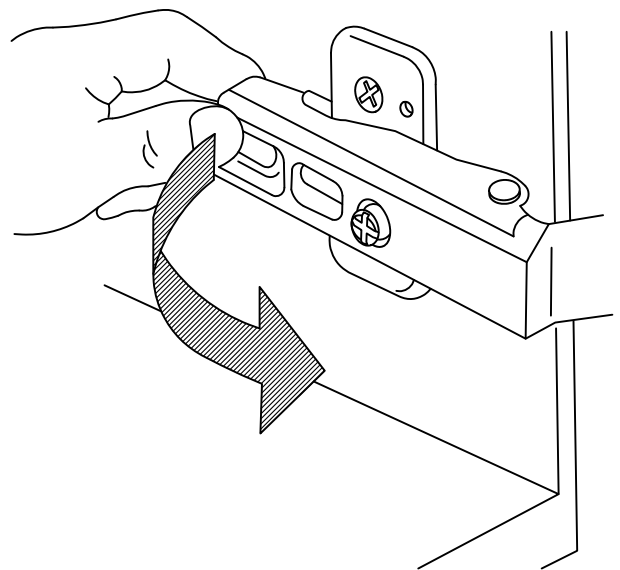

next

HAMPTON GENTS WARDROBE

Assembly Instructions

Actual product size

H203.5 x W120 x D62

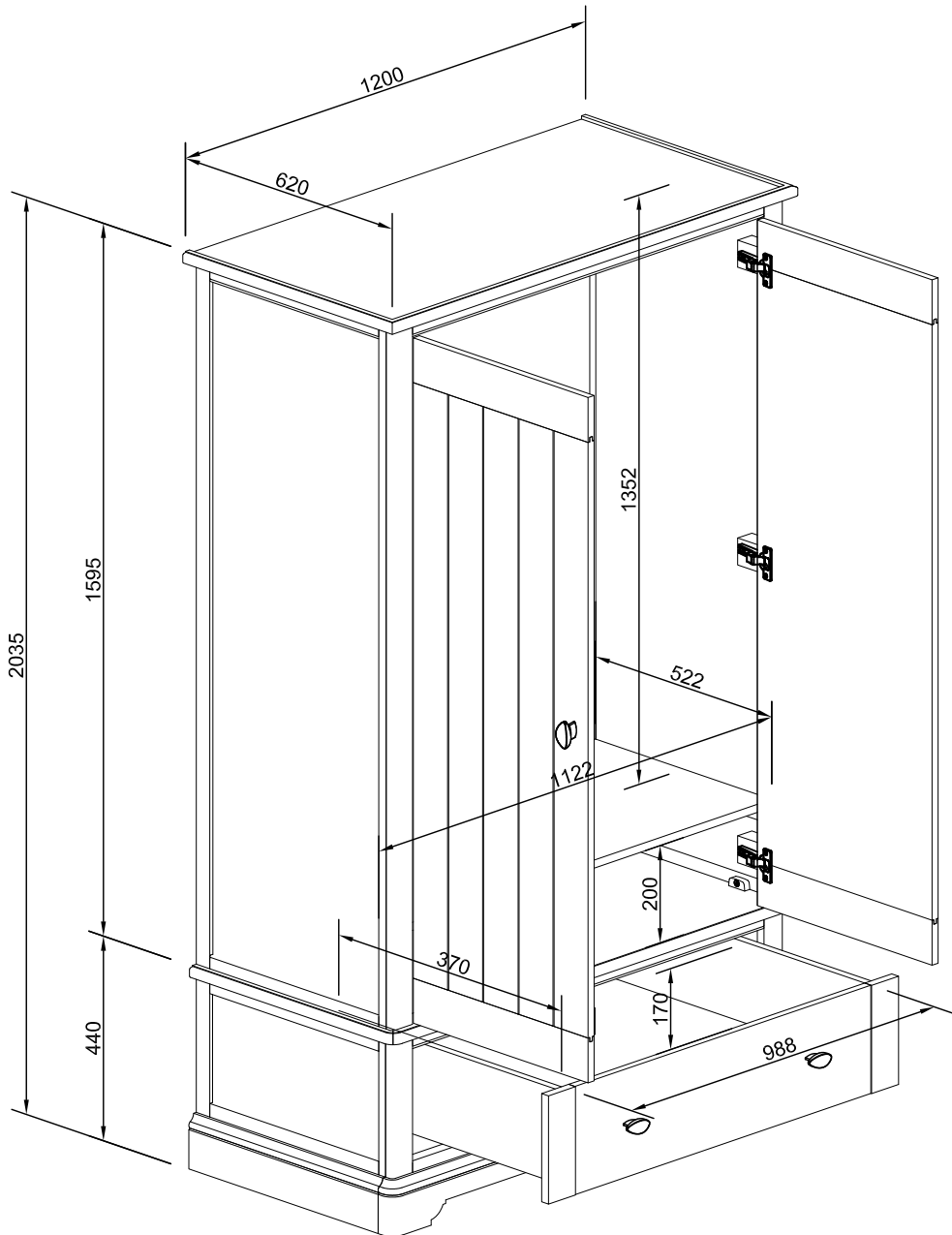



HAMPTON GENTS WARDROBE

Assembly instructions

Warnings

We suggest you retain these instructions for future reference.

Keep fittings out of children's reach and keep children well away from construction area.

This product should only be used on firm, level ground.

Please periodically check all fittings and re-tighten as necessary.

Please do not sit or stand on your furniture.

Avoid exposing the furniture to excessive heat or direct sunlight as this can cause deterioration of the colour.

Unwrap all packaging materials and place the components on top of the box or on a clean floor to protect it from damage.

PRODUCT SUPPLIED WITH WALL BRACKET

Missing parts

If you are missing any fixtures and fittings for your product, please contact our customer service team on 0333 777 8999, and they will be happy to arrange for a replacement to be sent to you free of charge.

Home service technicians

If you have a fault with your product, please contact our customer service team on 0333 777 8999. If you have had the product for 28 days or less you may be offered a replacement, refund or for a fully trained home service technician to visit your home to assess the fault and repair the product where possible.

If you have had the product for more than 28 days we will send an independent home service technician to review and repair the product where possible and recommend further action.

You can write to us at

Home Customer Services
Next Retail Ltd,
Desford Road,
Leicester,
LE19 4 AT

To View our full furniture range please visit [www. next.co.uk](http://www.next.co.uk)