

BEFORE YOU GET STARTED...

We're confident you'll love your gorgeous new Next furniture. However, it's worth making absolutely certain before you put it all together.

So, let's quickly run through these three steps:

1. COLOUR

Make sure you're happy with the colour
No need to unpack everything, just check the first component.

2. PROTECTIVE PACKAGING

If you're happy, then it's time to get opening! Start by laying everything out on the protective packaging – this will prevent anything getting scratched.

3. PARTS PAGE

Finally, double check you have all the pieces by referencing the parts page of the instructions.

TIPS FOR RETURNS

Not completely happy with the product? No problem. We just need everything back in the original packaging, so follow the steps below and this will ensure a super-smooth returns process and no delay to your refund.

DO



- Check everything is there (the 'parts page' is a handy checklist).
- Pop all the loose fittings and fixtures into the packaging provided or tie them up in a plastic bag.
- Wrap all the big components back up in the original protective packaging.
- Close up the box and seal it securely (don't be afraid to use plenty of tape).

DON'T



- Leave anything assembled - all components should be dismantled and separately packed.
- Put loose fixtures and fittings straight into the box.
- Throw it back in the box carelessly – as it may get damaged.

next
HOME

Then just give us a call on 0333 777 8999 and we'll sort out a pick up time for you.

next

N KENDALL SML SB PRQ

445997

Assembly instructions

Actual product size
H103 x W97.5 x D38cm

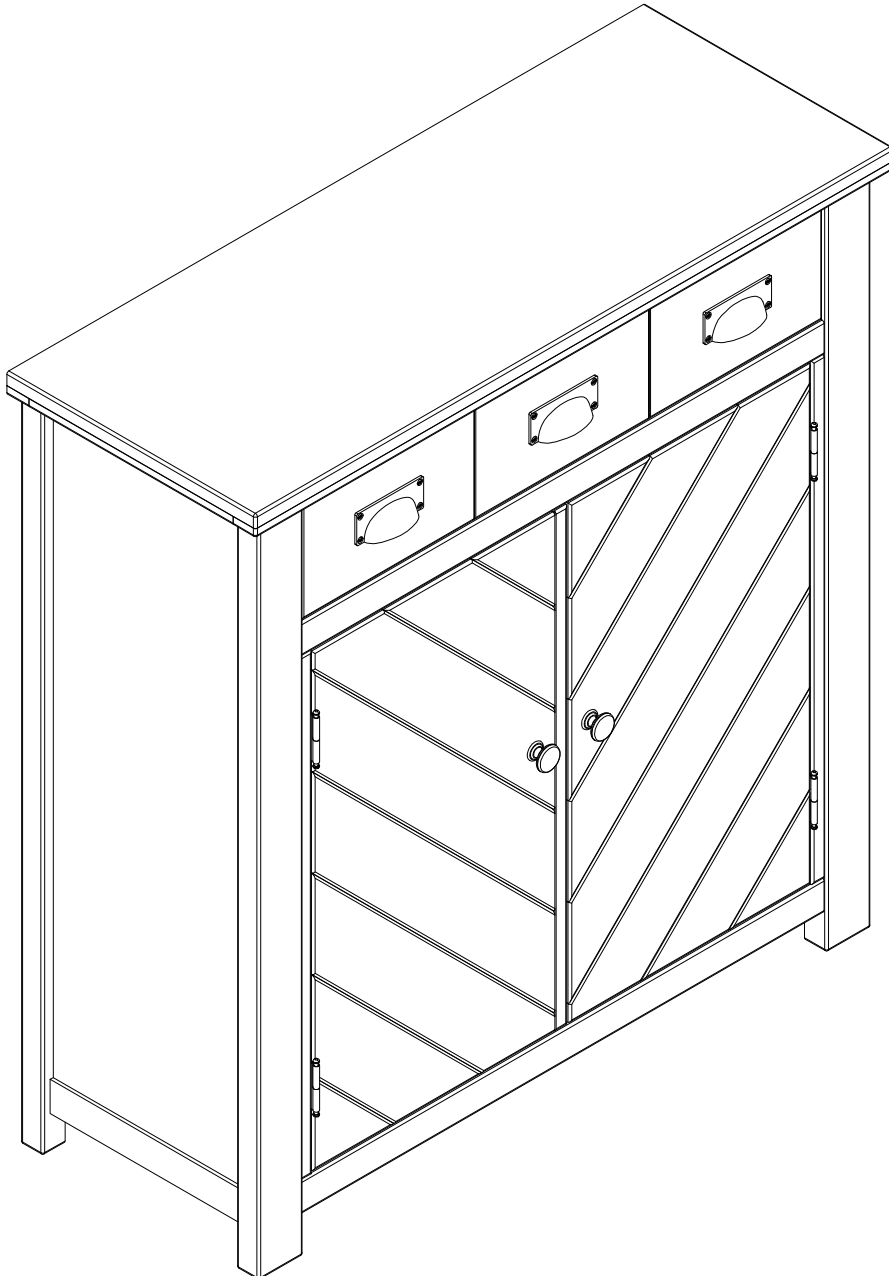

Need Help?

With: Assembly instructions
Missing or damaged parts

CALL: 0333 777 8999

IMPORTANT – RETAIN FOR FUTURE REFERENCE

BEFORE YOU START

Number of people required to assemble

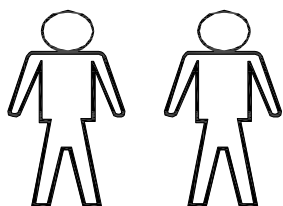

Time to assemble



15 min

Tools required

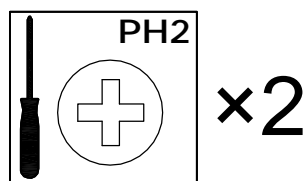

not supplied

Do's

We suggest you spend a short time reading through this leaflet before you start.

We recommend that the packaging is used to protect the surfaces during assembly.

Carefully check that you have all the parts before beginning assembly.

Due to the size of the product we recommend that it is assembled in the room intended for use.

Ensure the product is fully assembled as illustrated and all fixings fully tightened before use.

Wood will mellow and change colour over time, we recommend that ornaments and items placed on the surface are moved regularly for the first few months to prevent uneven mellowing.

Don'ts

Do not drag or pull your furniture.

Do not use silicone based furniture polish, Silicone in furniture polishes can break down the lacquer finish,

Never allow any kind of liquid to remain on your furniture. Absorption can cause wood to warp or finishes to de-laminate.

Do not place hot items (e.g. hot drinks) directly on to the wood surface. please make sure you use a placemat or coaster.

GETTING TO KNOW YOUR PRODUCT

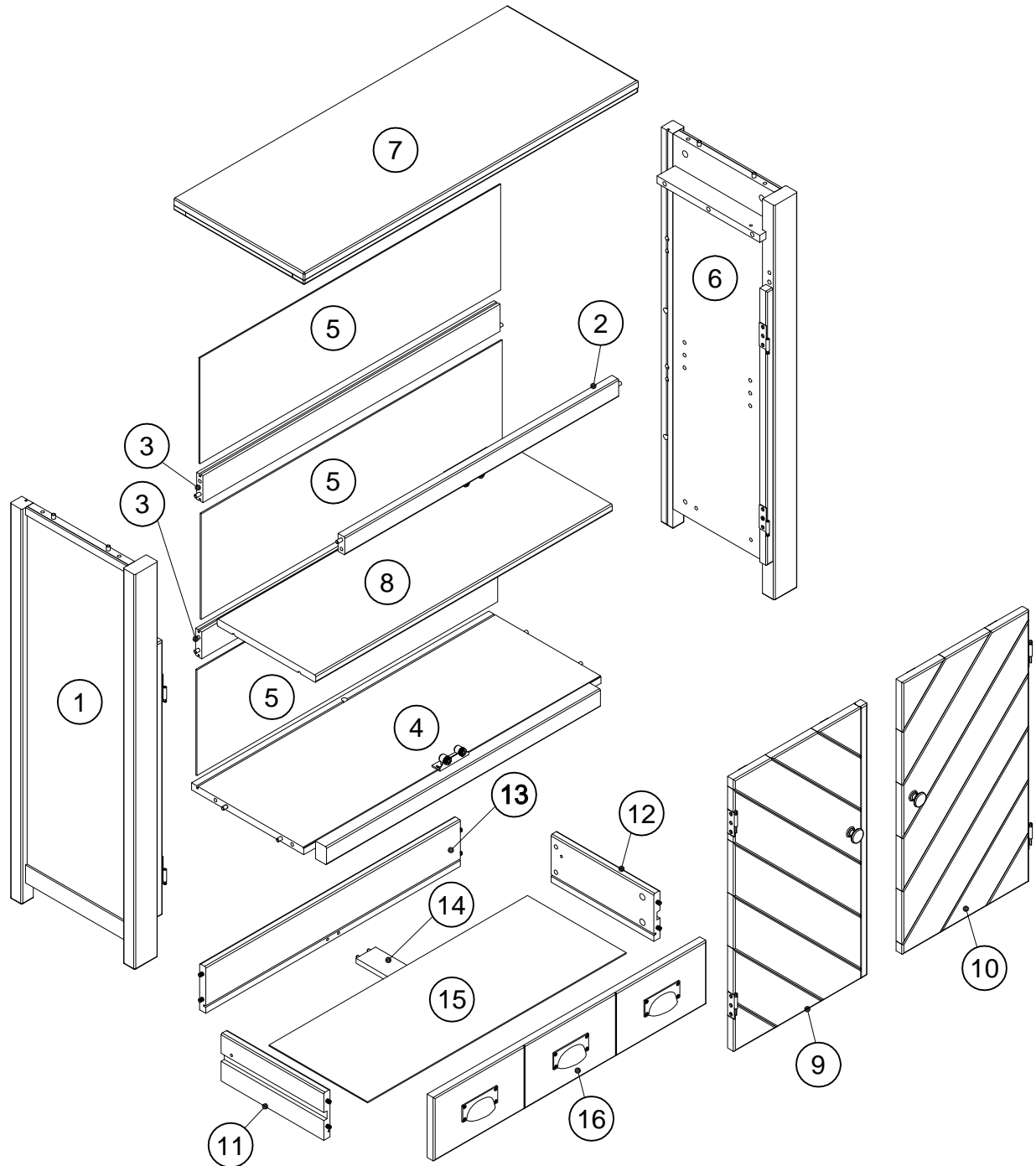

Fixtures and fittings
supplied (actual size)

Ref	Dimensions	Qty	Spare Qty
101	10×43.5mm	14	2
201	15×12mm	22	2
301	12×10mm	8	1
401	6×16mm	4	1
501	6×30mm	4	1

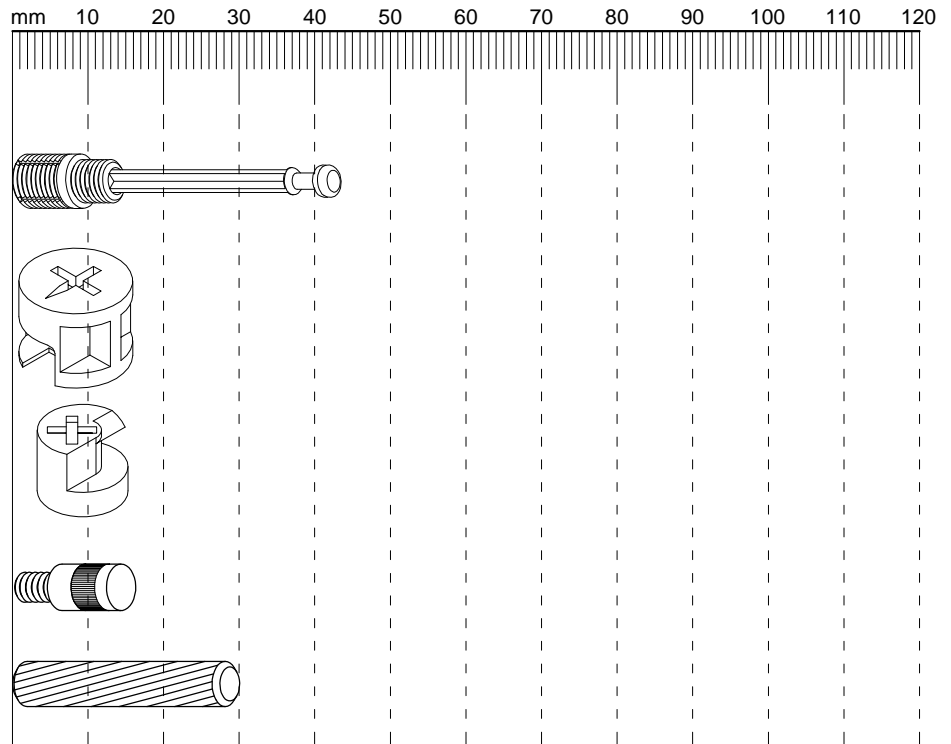





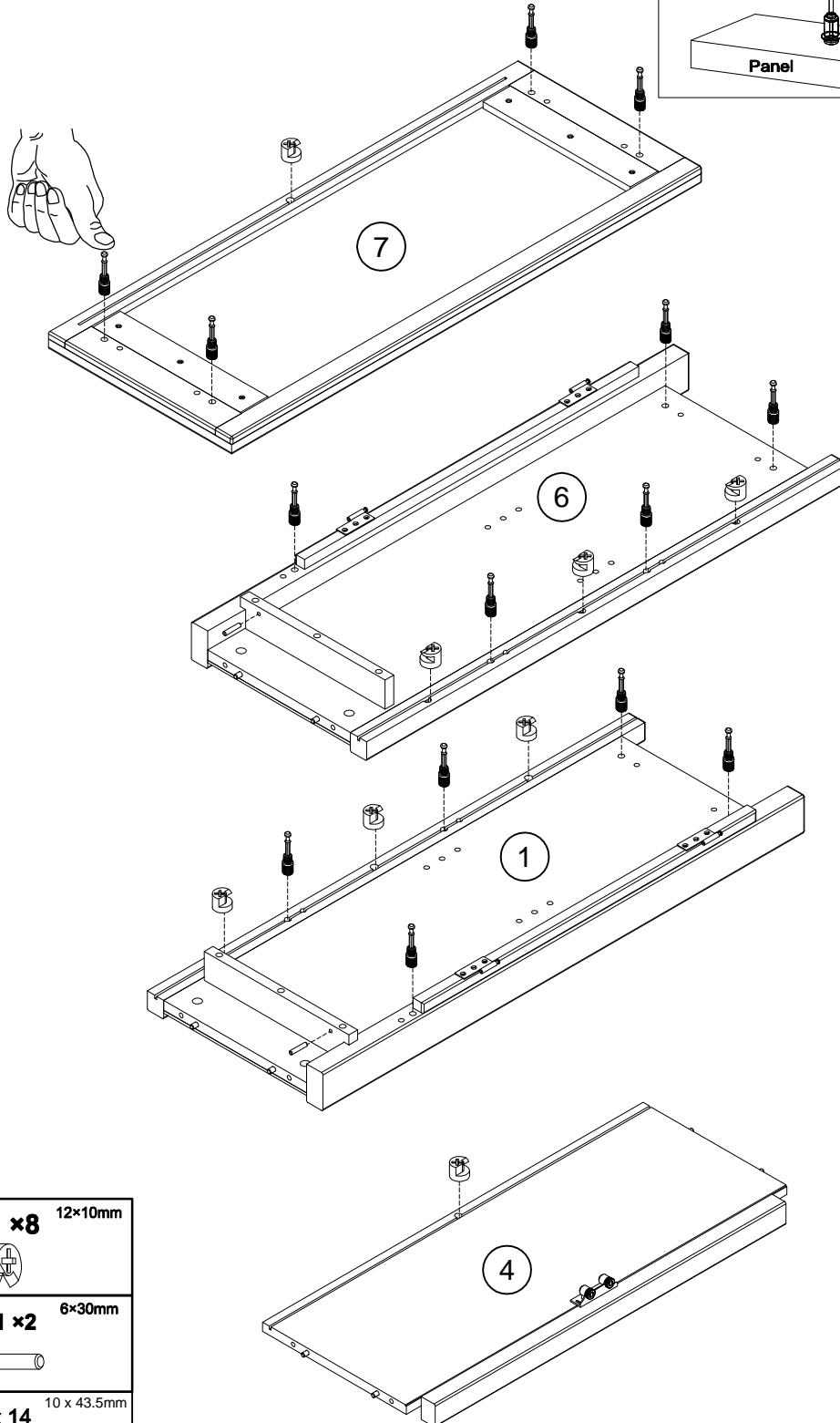
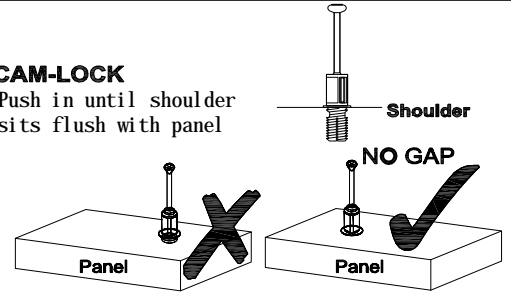

Components supplied. Please use this guide if you require replacement parts.

Ref	Dimensions	Visual	Qty	Ctn	Ref	Dimensions	Visual	Qty	Ctn
1	100x 36.4cm		1	1	9	68.7 x 38.9cm		1	1
2	80 x 4.5cm		1	1	10	68.7 x 36.9cm		1	1
3	86.8 x 6.8cm		2	1	11	30 x 12cm		1	1
4	86.8 x 36cm		1	1	12	30 x 12cm		1	1
5	87.9 x 26.7cm		3	1	13	74.4x11.7cm		1	1
6	100 x 36.4cm		1	1	14	27.7x 5.7cm		1	1
7	97.6 x 38cm		1	1	15	75.5 x 28.8cm		1	1
8	86.6 x 28.8cm		1	1	16	79.6 x 16cm		1	1

1

CAM-LOCK
Push in until shoulder
sits flush with panel



 not supplied	301 x 8 	12x10mm
 not supplied	501 x 2 	6x30mm
 not supplied	101 x 14 	10 x 43.5mm

2

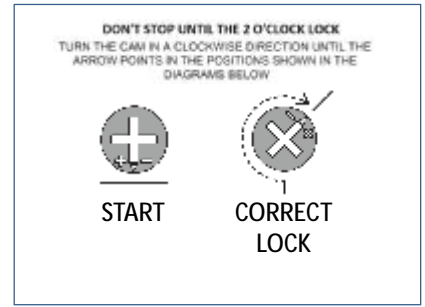
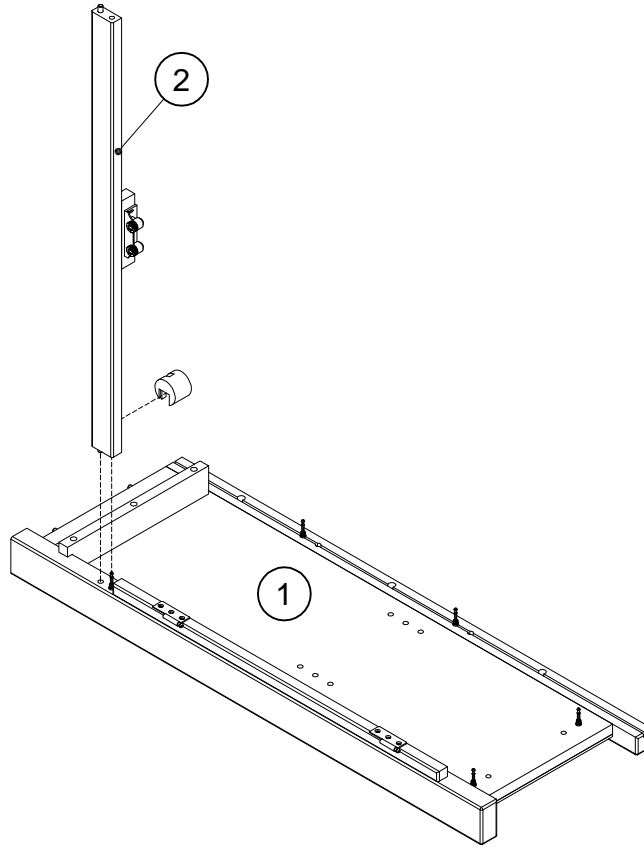

3

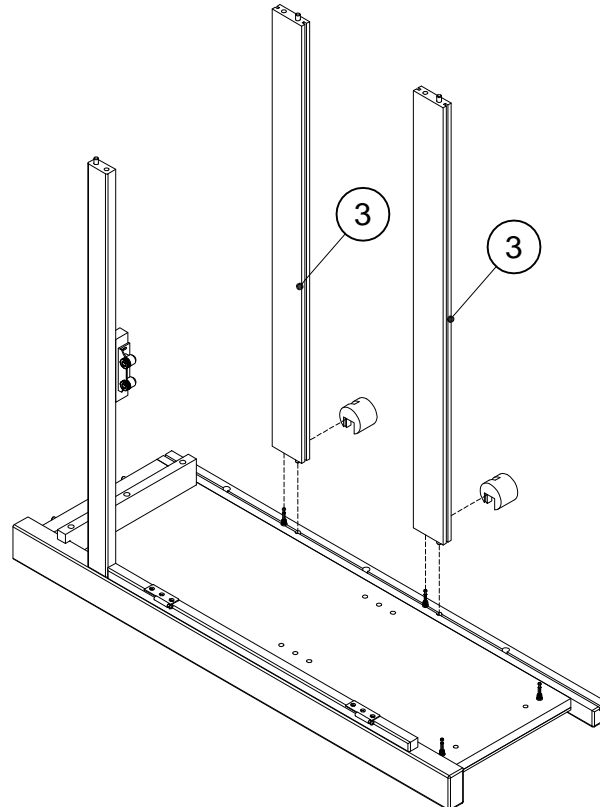

4

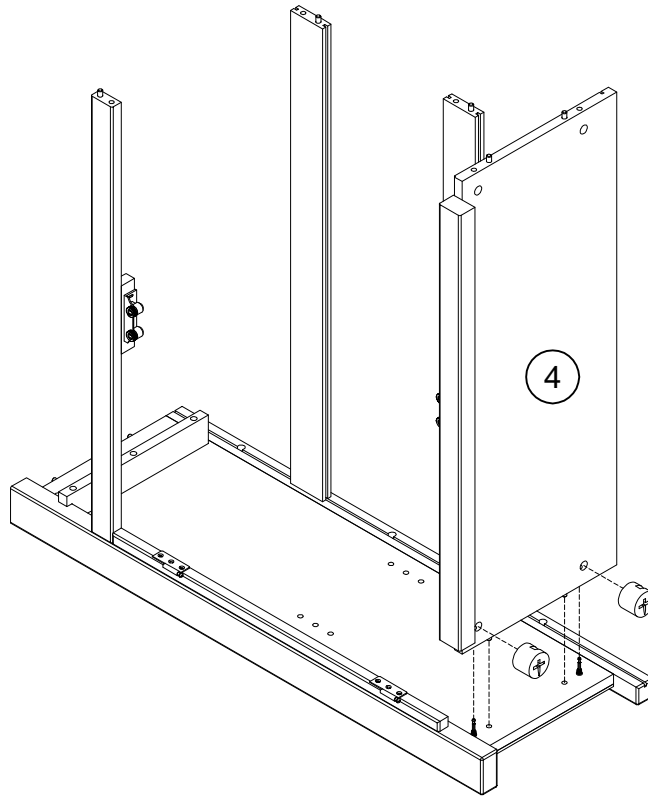

201 x2

15x12mm



5

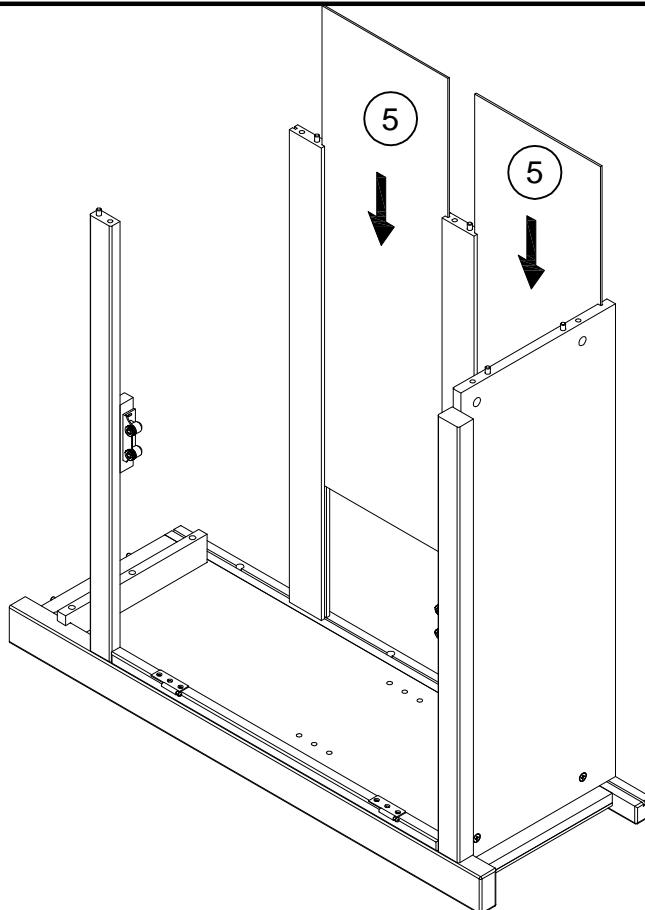

6

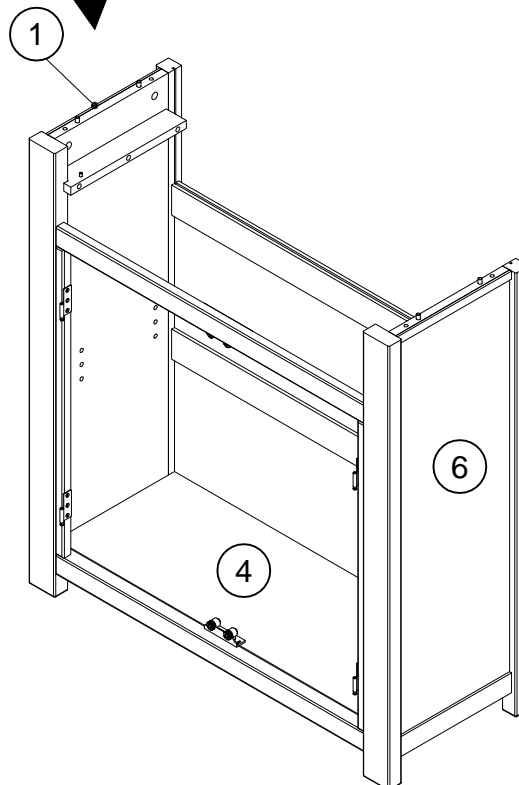
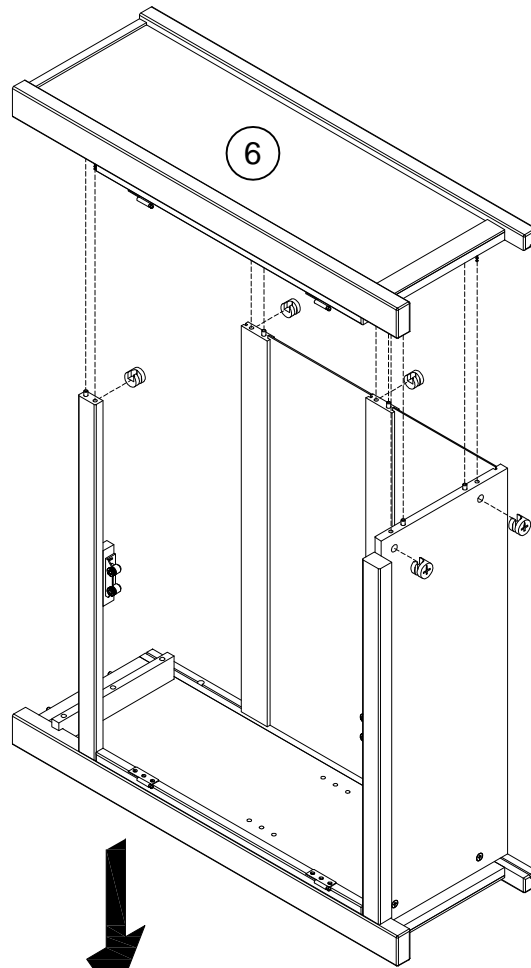

7

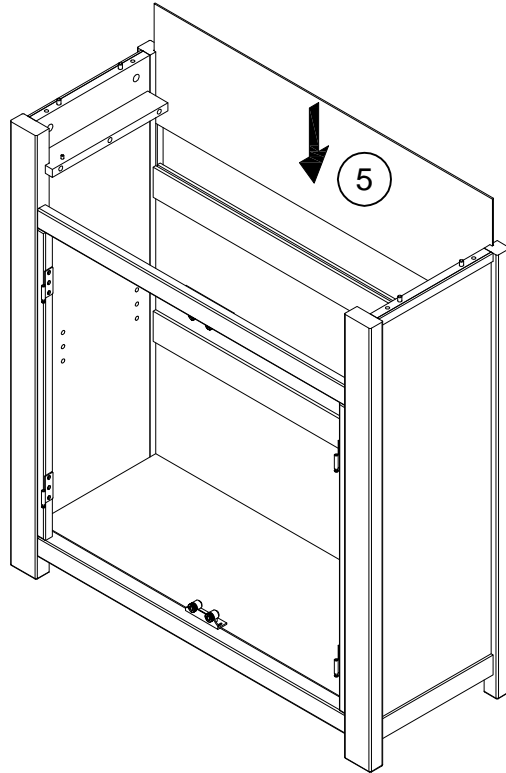

8

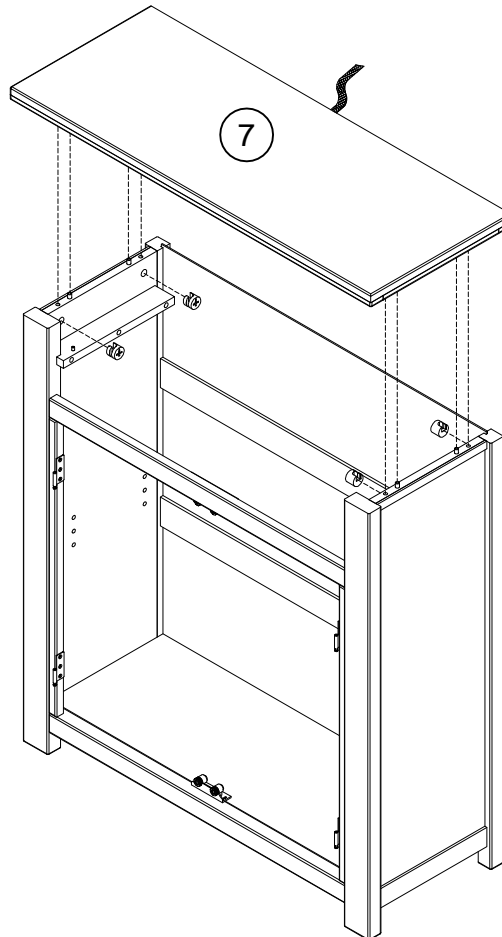

201 x4

15x12mm



not supplied

9



Please turn the camlock clockwise 90 degree to fasten the backboard.

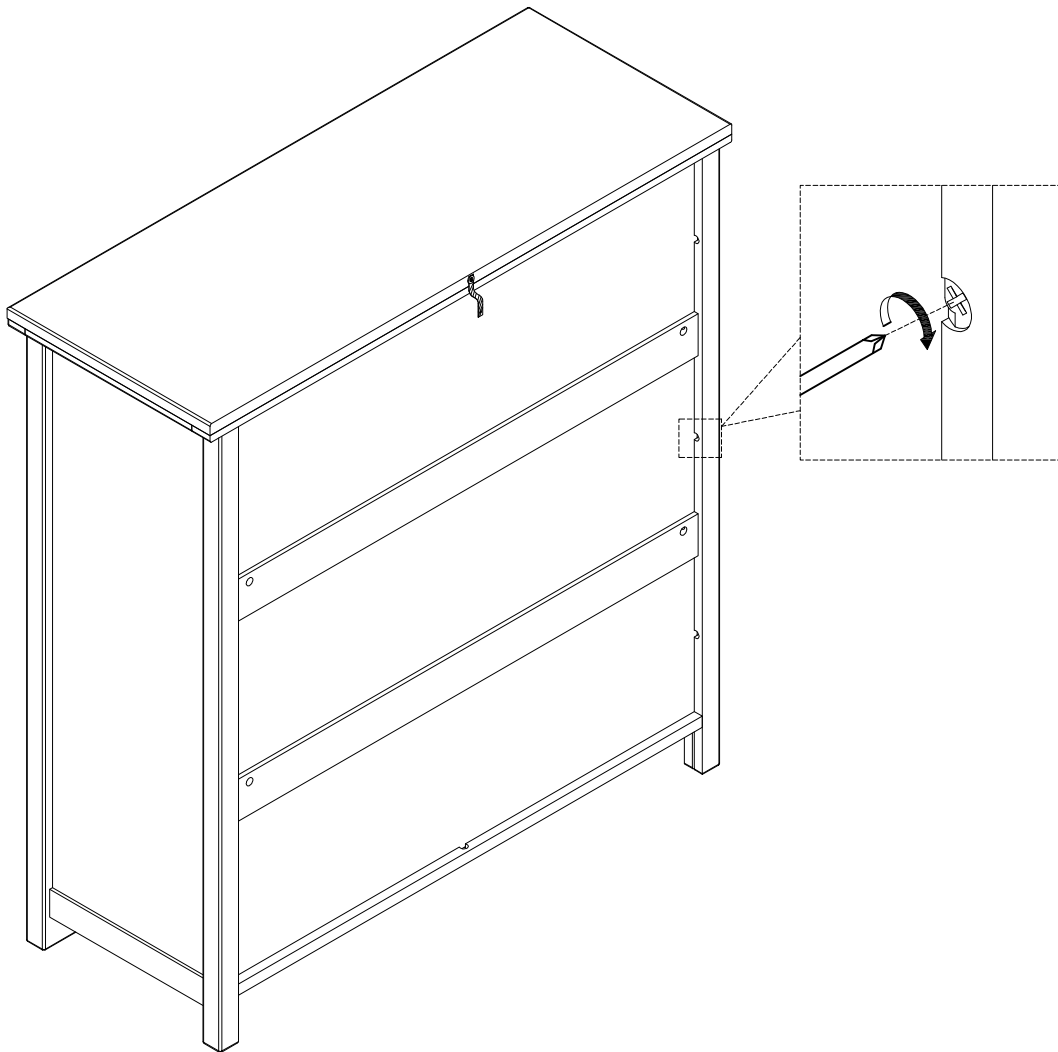

10

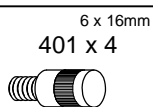
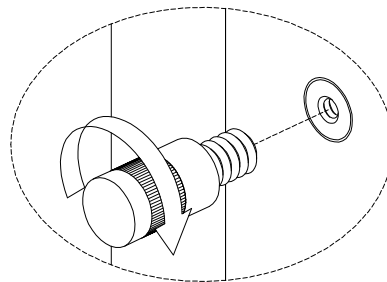
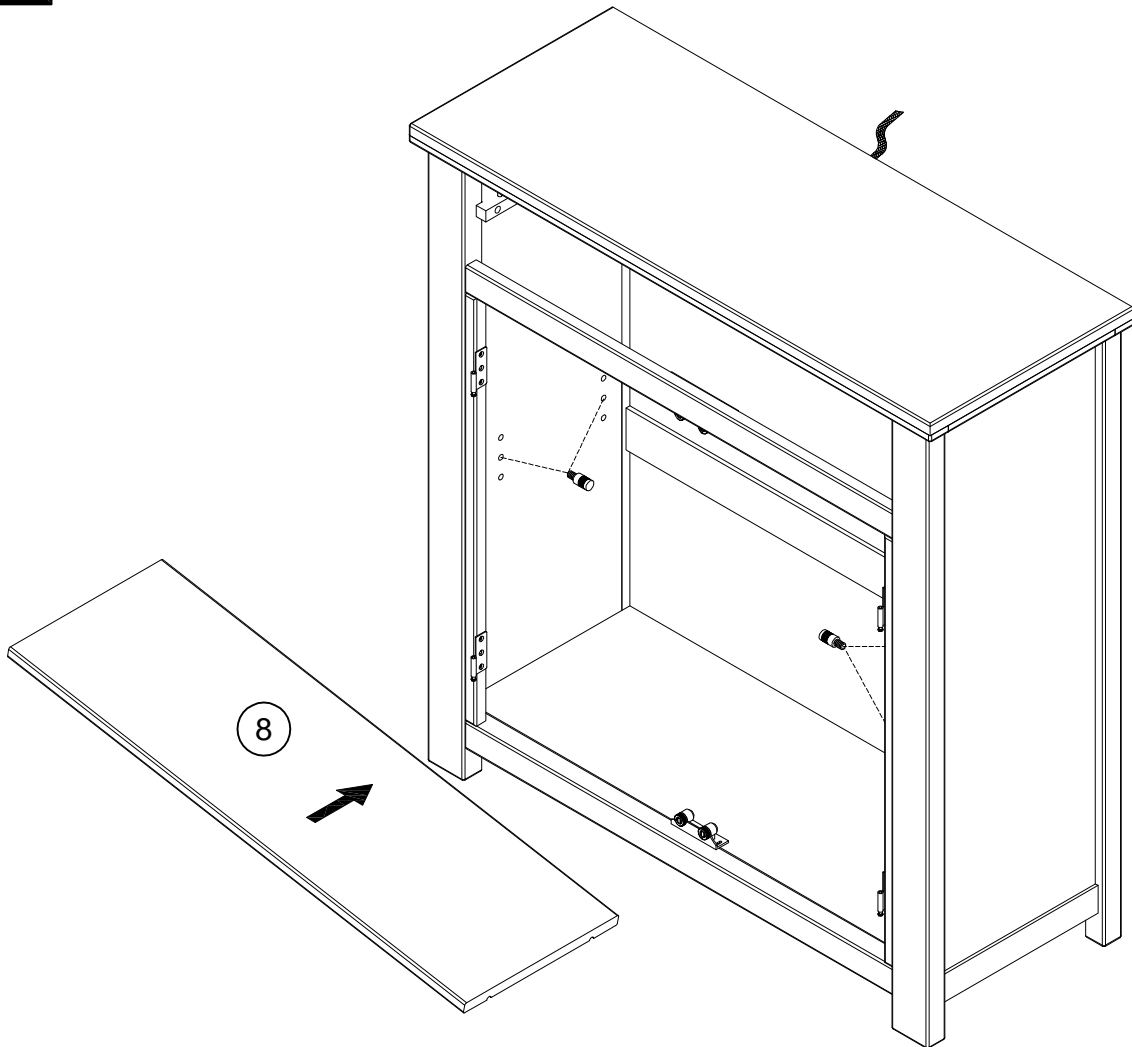

11

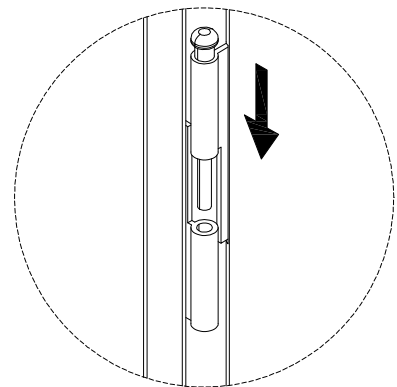
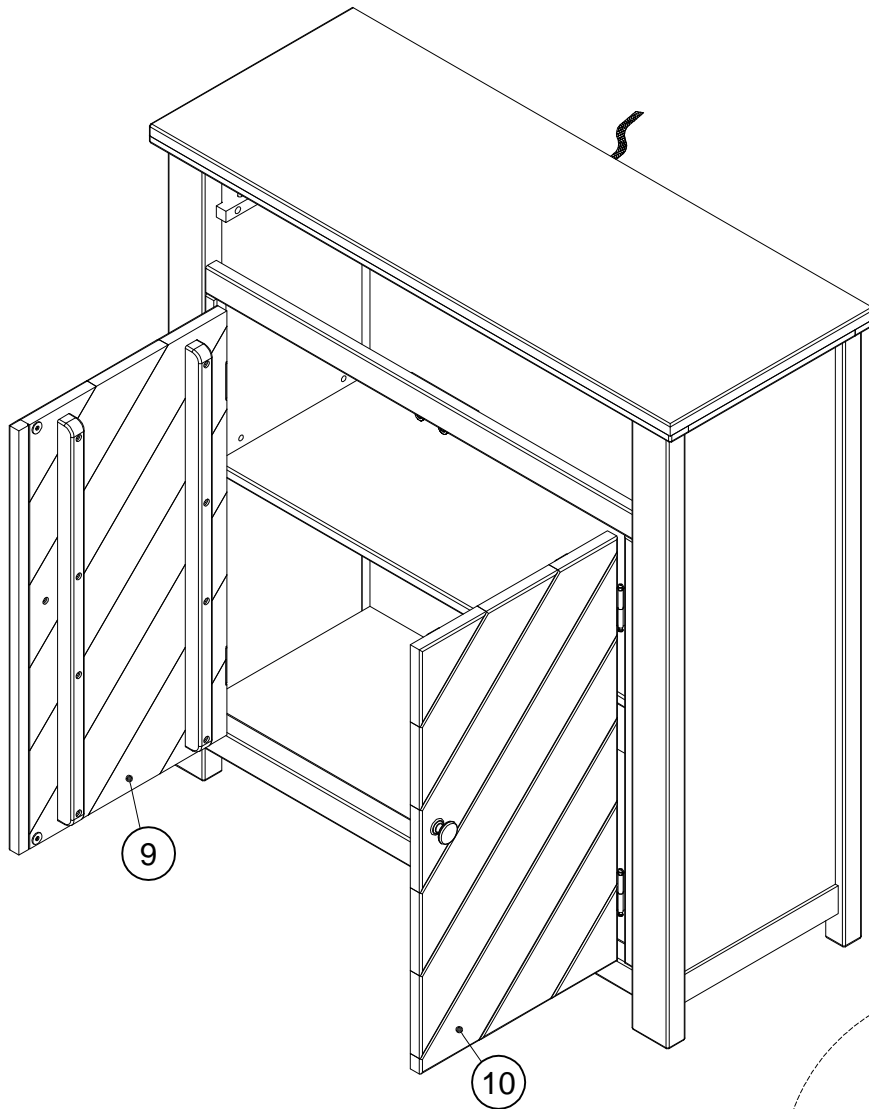

12

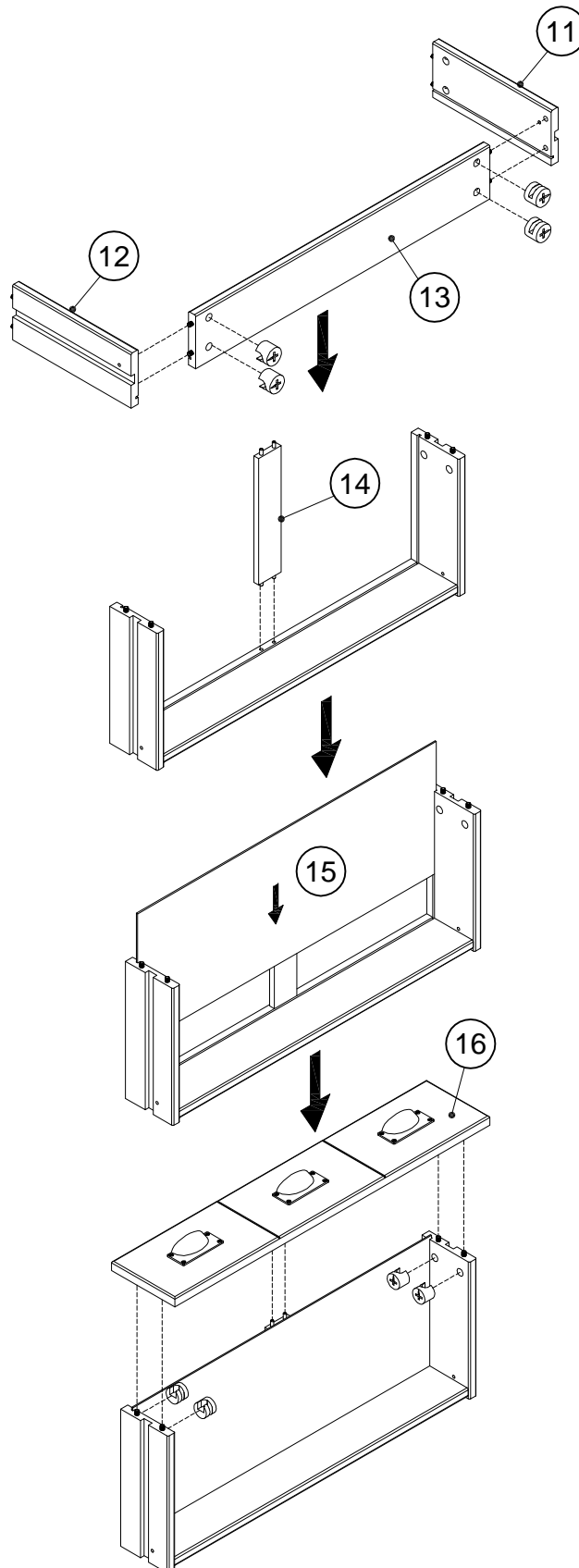

201 x8

15x12mm



not supplied

13

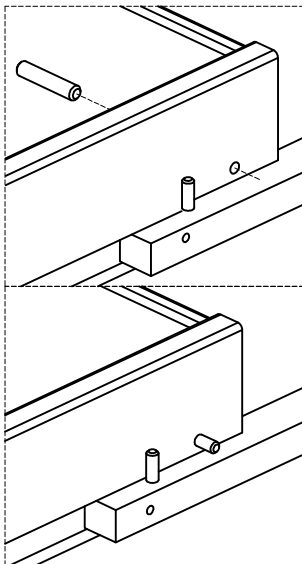
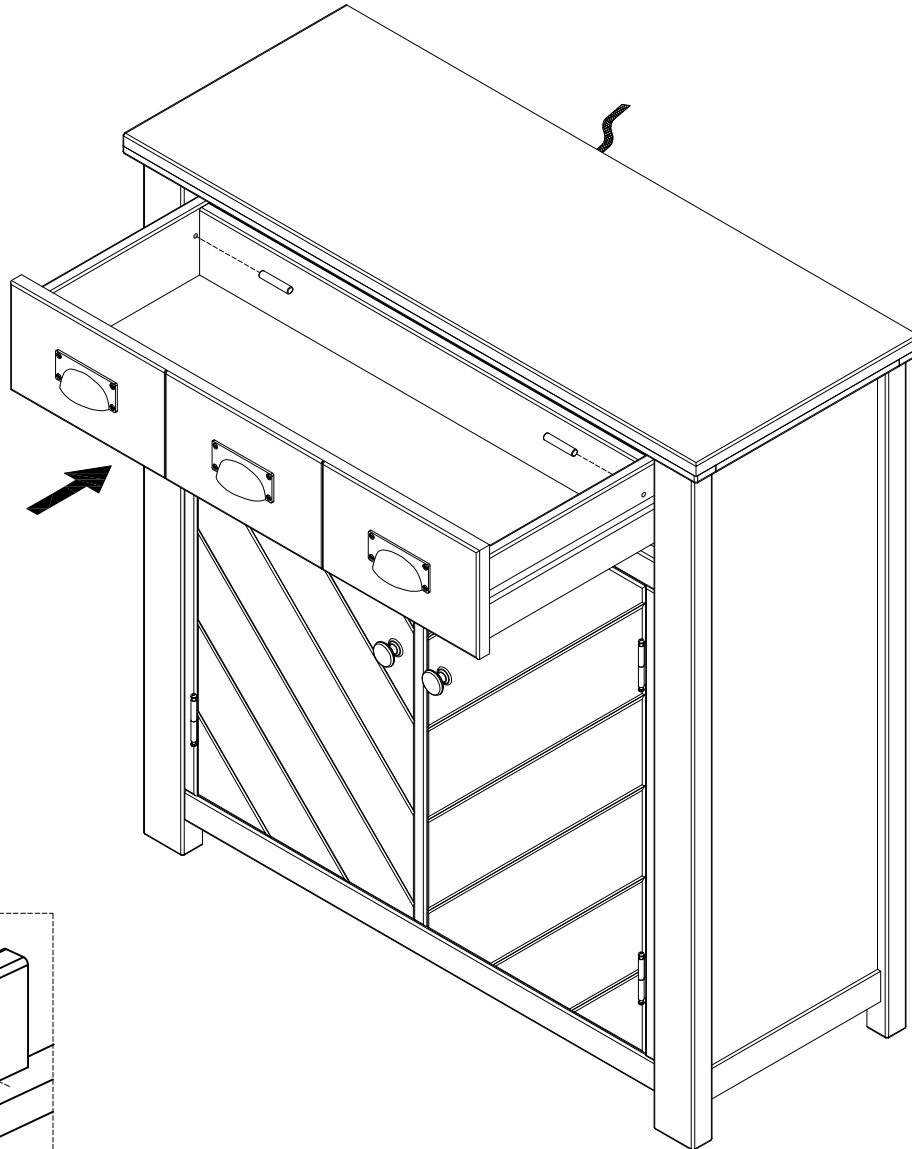

501 x2 6x30mm

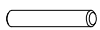

not supplied

14



1. Move the item into position and attach the end of the strap to the wall with the appropriate screw, washer and wall plug for your wall type .
2. **WARNING:** Always ensure the area to be drilled is free from hidden electrical wires, water and gas pipes.
3. **NOTE:** Wall fixings are not included , please source suitable fixings for your wall type, if in doubt, please consult a qualified tradesman.

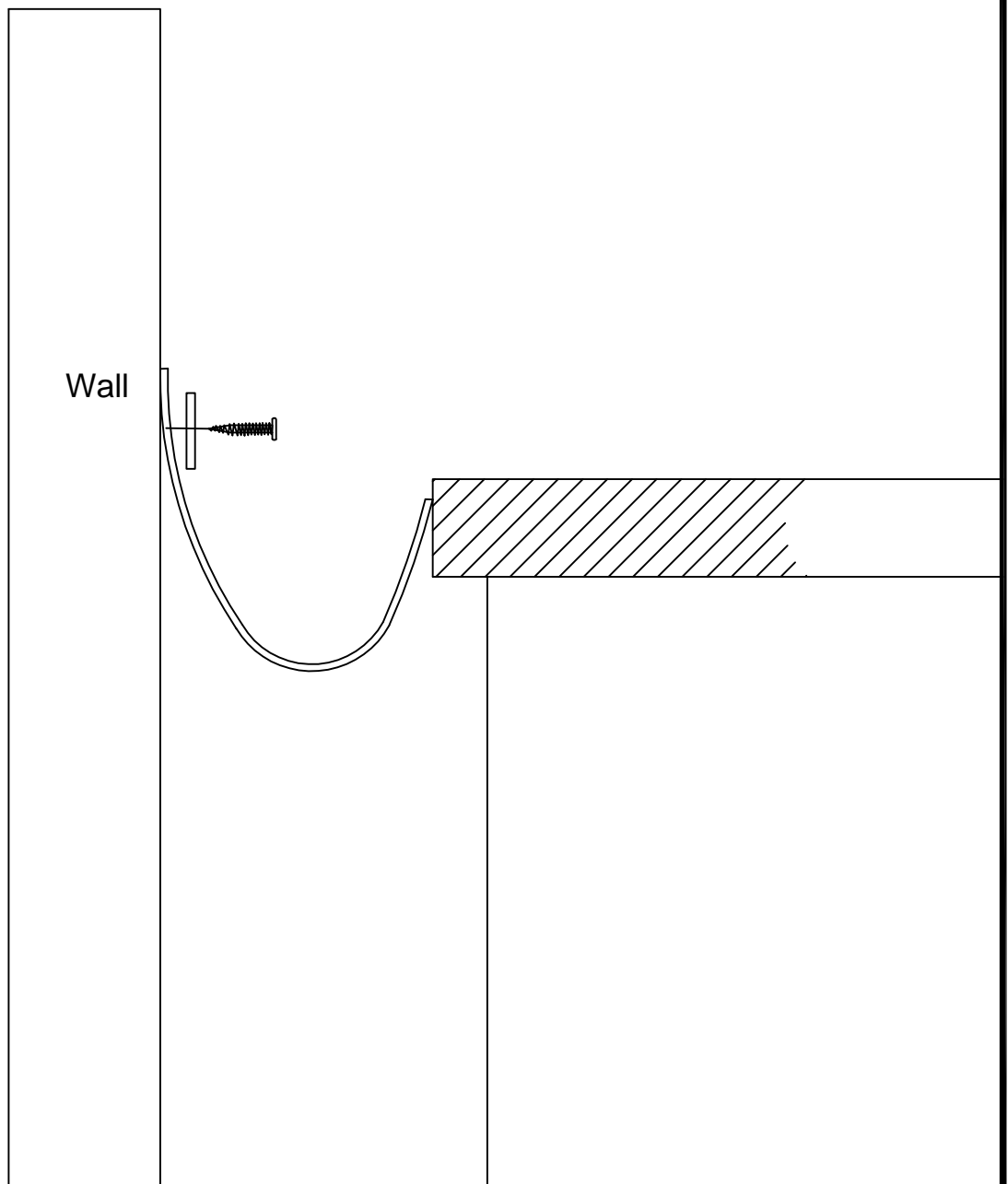

next

N KENDALL SML SB PRQ

445997

Assembly instructions

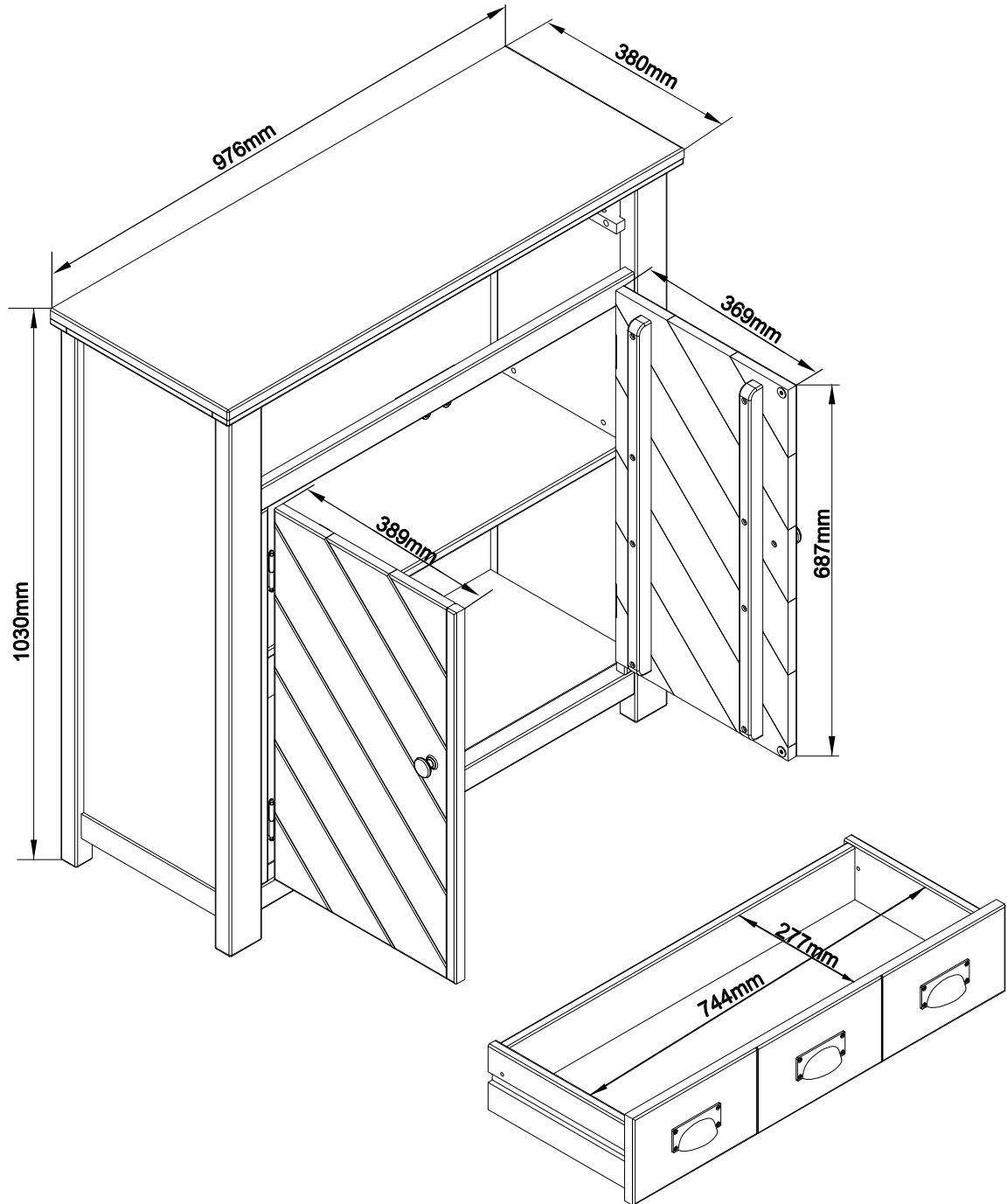



N KENDALL SML SB PRQ
445997
Assembly instructions

Warnings

We suggest you retain these instructions for future reference.

Keep fittings out of children's reach and keep children well away from the construction area.

This product should only be used on firm, level ground.

Please periodically check all fittings and re-tighten as necessary.

Please do not sit or stand on your furniture.

Avoid exposing the furniture to excessive heat or direct sunlight as this can cause deterioration of the colour.

Unwrap all packaging materials and place the components on top of the carton box or on a clean floor to protect it from damage.

Missing parts

If you are missing any fixtures and fittings for your product please contact our customer service team on **0333 777 8999** and they will be happy to arrange for a replacement to be sent to you free of charge.

Home service technicians

If you have a fault with your product please contact our customer service team on **0333 777 8999**. If you have had the product for 28 days or less you may be offered a replacement, refund or for a fully trained home service technician to visit your home to assess the fault and repair the product where possible. If you have had the product for more than 28 days we will send an independent home service technician to review and repair the product where possible and recommend further action.

You can write to us at

Home Customer Services

Next Retail Ltd,
Desford Road,
Leicester,
LE19 4AT

To view our full furniture range please visit www.next.co.uk

PRODUCT SUPPLIED WITH WALL FIXING STRAPS