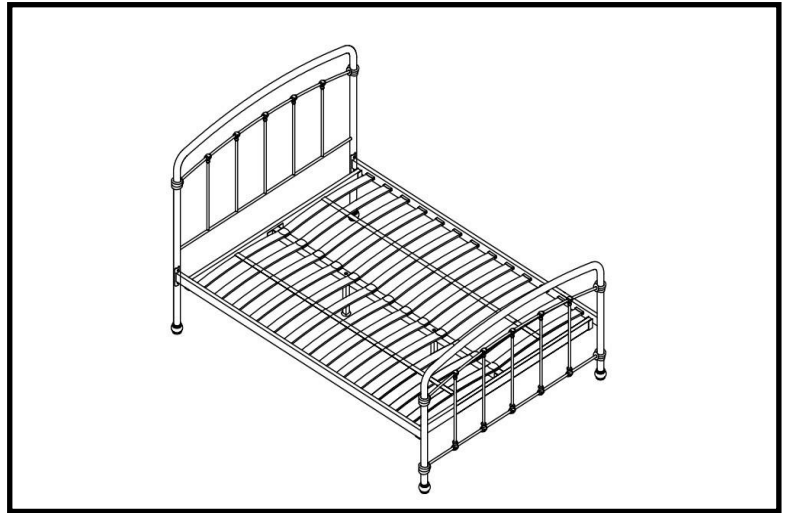
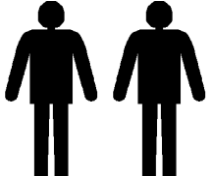

ASSEMBLY INSTRUCTIONS.**IMPORTANT - RETAIN FOR FUTURE REFERENCE - READ CAREFULLY.****Tools Needed****Helpline**

If you have any problems with this product or require any replacement fittings please contact Customer Services Tel: 0333 777 8999

Regrettably self assembly items cannot be returned once assembly is part or fully completed unless the item is found to be faulty. Should you need to return the unassembled product, please repack in the original packaging

IMPORTANT

- We suggest you spend a short time reading through this leaflet and then follow the simple step by step instructions.
- Carefully check that you have all parts before beginning assembly.
- Keep fittings out of children's reach and keep children well away from the construction area.
- We recommend that the packaging is used to protect the surfaces during assembly.
- A minimum of two persons is required to assemble this product.

PRODUCT INFORMATION

- Made from steel with an antique bronze plated finish and poplar sprung wooden slats.
- Made in China.

CARE INSTRUCTIONS

- For general cleaning, periodically dust with a soft cloth.
- Do not rub or scrub the surface when cleaning.
- Do not use abrasive cleaning products or those containing silicone.
- Any spills should be removed immediately with a soft clean damp cloth and dried immediately.
- Ensure the product is protected with mats and coasters when items are placed on the surfaces, to prevent scratching or damage.
- Do not put hot dishes directly on the surfaces of the item.
- Avoid keeping furniture in direct sunlight or close to any heat sources as this can cause cracking, discolouration or warping.
- Never drag pieces of furniture across the floor as this will cause damage to the joints.
- All assembly fixings should always be tightened properly and periodically check all fixings and tighten if necessary.

FITTINGS



**A. Bolts x12
M6X20mm**



**B. Bolts x4
M6X55mm**



**C. Nut x2
M6**



**D. Plastic Washer x8
M6**



**E. Metal Washer x 18
M6**



**F. Allen key x1
4mm**



**G. Spanner x 1
11mm**

PARTS

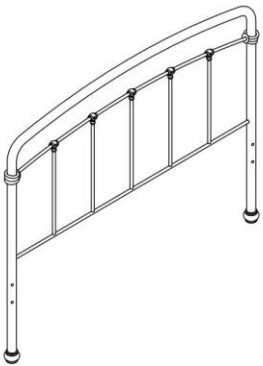

(1) Headboard x 1

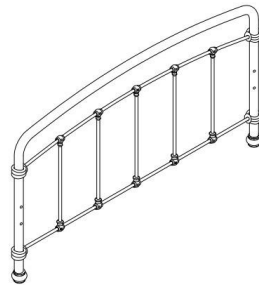

(2) Footboard x 1

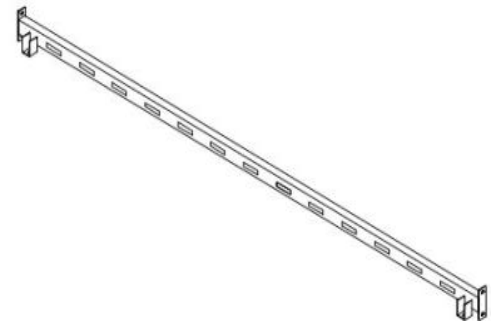

(3) Side Rail x 2

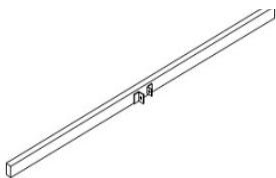

(4) Cross Bar x 2

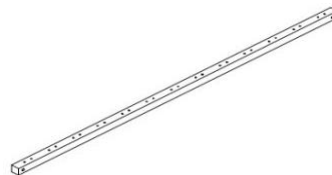

(5) Centre Rail x 1



(6) Sprung Slats x 26



**(7) Plastic cap (one
end open) x 26**



**(8) Plastic cap (two
end open) x 13**



9) Fabric straps 2



**(10) Support
Feet x 2**

STEP ONE

1. Attach side rails 3 (x2) to headboard 1 and footboard 2 using 8 x bolts (A), 8 x plastic washers (D) and 8 x metal washers (E). Tighten using Allen key (F)

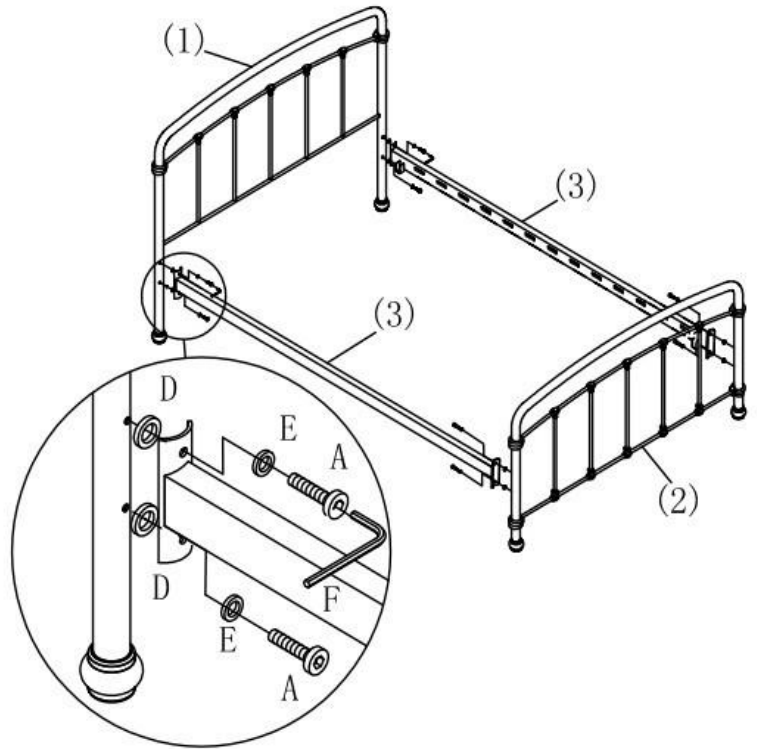

STEP TWO

1. Attach cross bars 4 (x2) to the brackets on side rails 3 (x2) using 4 x bolts (A) and 4 x metal washers (E). Tighten with Allen key (F).

NOTE: Ensure the threaded insert holes in cross bars 4 (x2) are facing downwards.

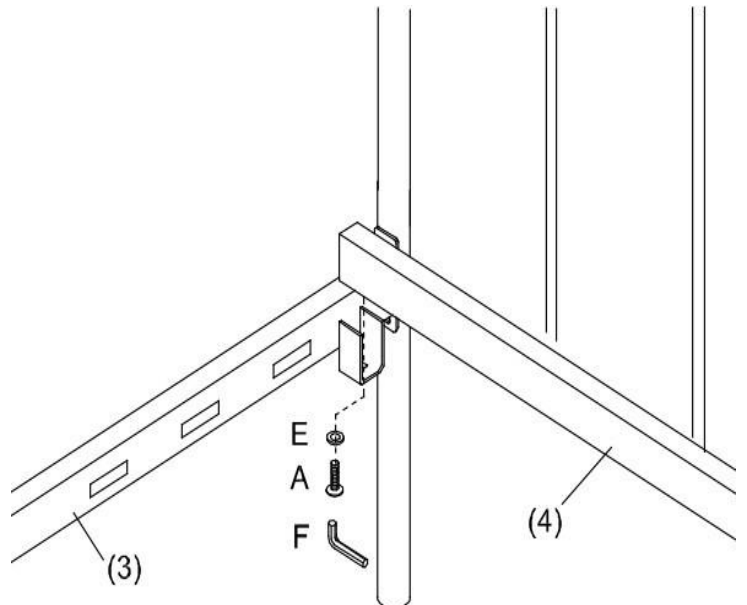

STEP THREE

1. Attach centre rail 5 between the brackets on cross bars 4 (x2) using 2 x bolts (B), 4 x metal washers (E) and 2 x nuts (C). Tighten with Allen key (F) and spanner (G).

NOTE: Please ensure that the slat cap holes on the centre rail 5 face upwards.

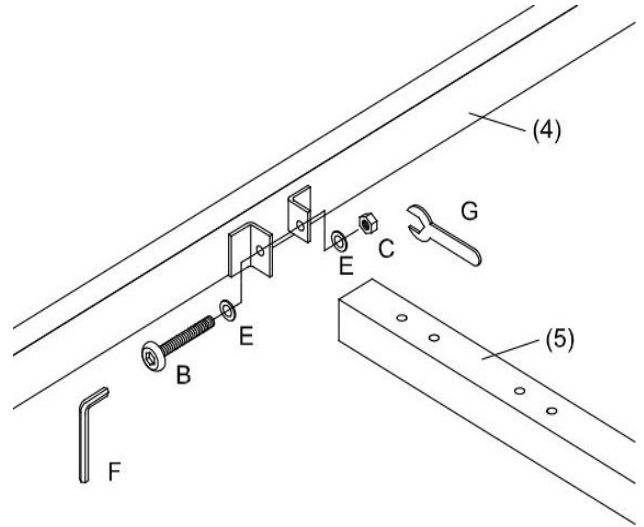

STEP FOUR

1. Attach 2 x support feet 10 to centre rail 5 using 2 x bolts (B) and 2 x metal washers (E). Tighten with Allen key (F).

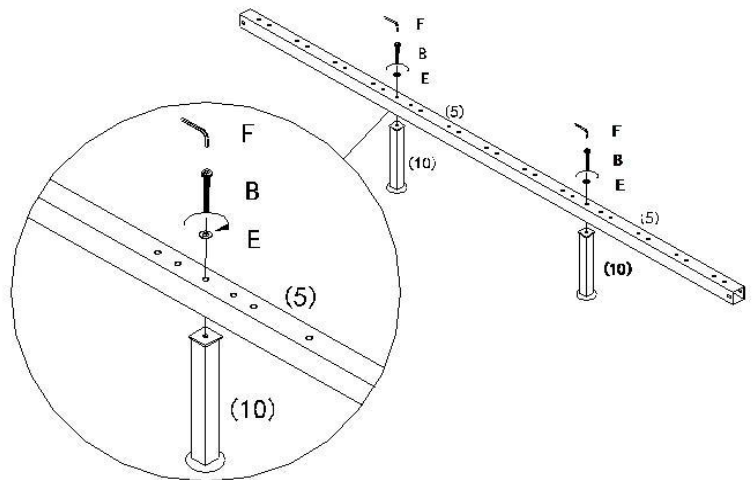

STEP FIVE

IMPORTANT

Once the feet have been assembled and attached, they should be adjusted to ensure they do not touch the floor, (5mm above the floor) to allow for movement once the mattress is placed on the bed frame.

It is important to note that when moving the bed that it is not dragged into its new position to prevent the possibility of these feet being twisted or angled to one side, which could lead to the collapse of the centre of the bed.

To move the bed, remove the mattress and lift the bed into its new position to avoid damage. Ensure the feet are at 90° to the floor before replacing the mattress.

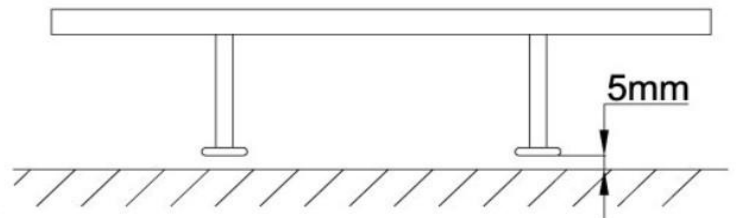

STEP SIX

1. Insert a sprung wooden slat 6 through the first hole in strap 9. Repeat using another sprung wooden slat 6 and the other strap 9.
2. Attach single sided slat cap 7 onto one end of the sprung wooden slat 6. Attach another single sided slat cap 7 onto the other end of the second sprung wooden slat 6.
3. Attach both sprung wooden slats to the assembled bed base by inserting each single sided slat cap 7 into side rails 3 (x2) and using double sided slat cap 8 in the centre. Once each slat has been inserted into the slat caps, ensure the double sided slat cap is firmly pushed into the holes in centre rail 5.
4. Repeat process for all remaining slats and caps until all components have been used and firmly pushed in place.

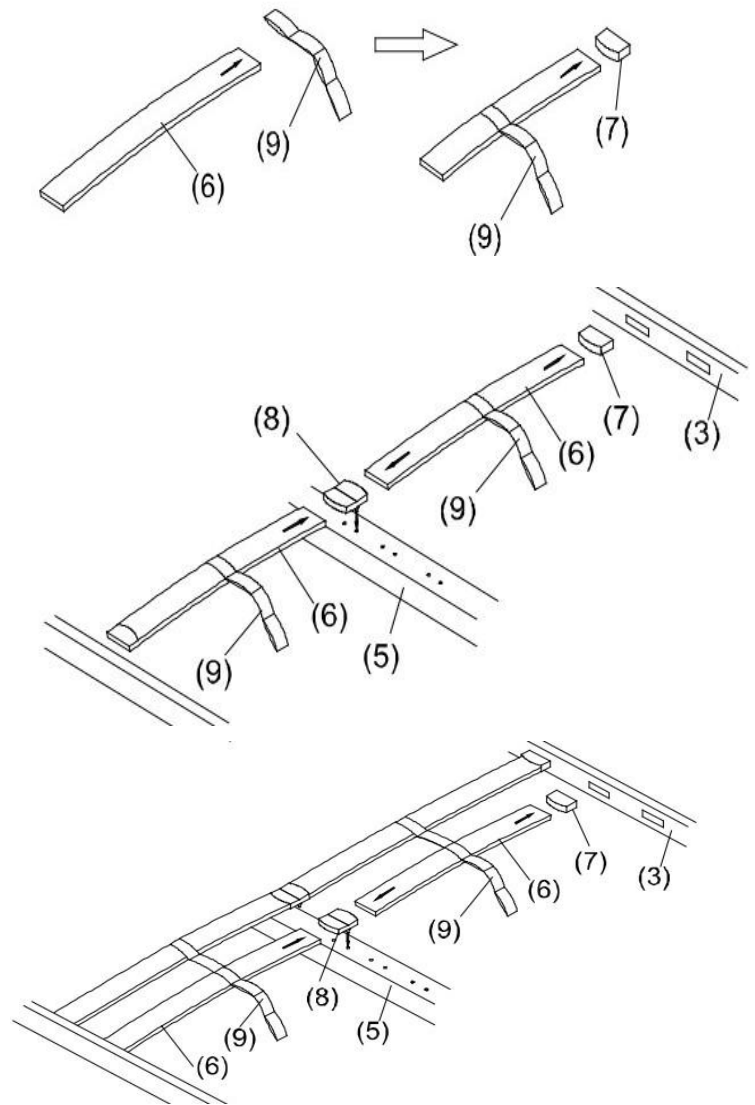

STEP SEVEN

