

BEFORE YOU GET STARTED...

We're confident you'll love your gorgeous new Next furniture. However, it's worth making absolutely certain before you put it all together.

So, let's quickly run through these three steps:

1. COLOUR

Make sure you're happy with the colour
No need to unpack everything, just check the first component.

2. PROTECTIVE PACKAGING

If you're happy, then it's time to get opening! Start by laying everything out on the protective packaging – this will prevent anything getting scratched.

3. PARTS PAGE

Finally, double check you have all the pieces by referencing the parts page of the instructions.

TIPS FOR RETURNS

Not completely happy with the product? No problem. We just need everything back in the original packaging, so follow the steps below and this will ensure a super-smooth returns process and no delay to your refund.

DO



- Check everything is there (the 'parts page' is a handy checklist).
- Pop all the loose fittings and fixtures into the packaging provided or tie them up in a plastic bag.
- Wrap all the big components back up in the original protective packaging.
- Close up the box and seal it securely (don't be afraid to use plenty of tape).

DON'T



- Leave anything assembled - all components should be dismantled and separately packed.
- Put loose fixtures and fittings straight into the box.
- Throw it back in the box carelessly – as it may get damaged.

next
HOME

Then just give us a call on 0333 777 8999 and we'll sort out a pick up time for you.

next

N KENDALL TALL SHELF

427377/975339

Assembly instructions

Actual product size

H200.1 x W88 x D35cm

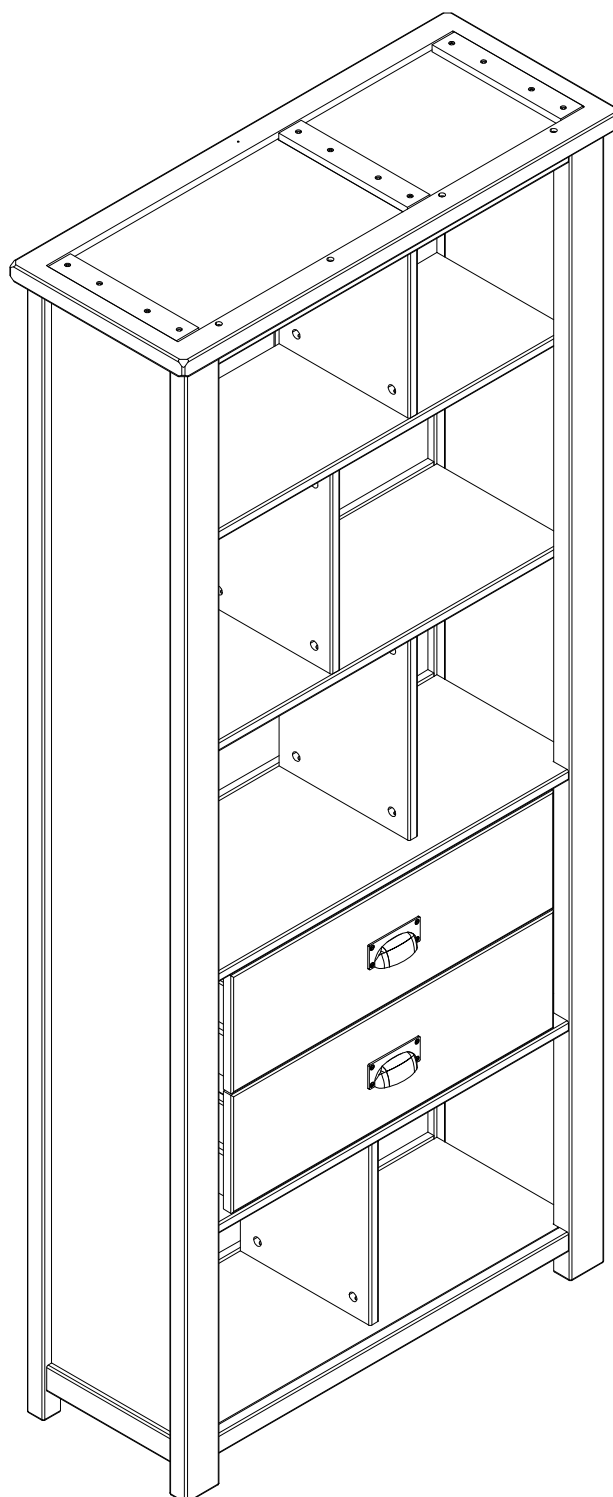

IMPORTANT - RETAIN FOR FUTURE REFERENCE

Need Help?

With: Assembly instructions
Missing or damaged parts

CALL: 0333 777 8999

BEFORE YOU START

Number of people required to assemble

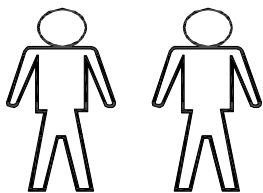

Time to assemble



Do's

We suggest you spend a short time reading through this leaflet before you start.

We recommend that the packaging is used to protect the surfaces during assembly.

Carefully check that you have all the parts before beginning assembly.

Due to the size of the product we recommend that it is assembled in the room intended for use.

Ensure the product is fully assembled as illustrated and all fixings fully tightened before use.

Wood will mellow and change colour over time, we recommend that ornaments and items placed on the surface are moved regularly for the first few months to prevent uneven mellowing.

Don'ts

Do not drag or pull your furniture.

Do not use silicone based furniture polish, Silicone in furniture polishes can break down the lacquer finish,

Never allow any kind of liquid to remain on your furniture. Absorption can cause wood to warp or finishes to de-laminate.

Do not place hot items (e.g. hot drinks) directly on to the wood surface. please make sure you use a placemat or coaster.

Tools required

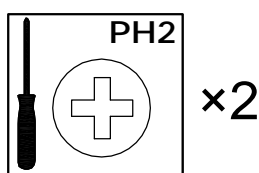

not supplied

N KENDALL TALL SHELF

427377/975339
Assembly instructions

GETTING TO KNOW YOUR PRODUCT

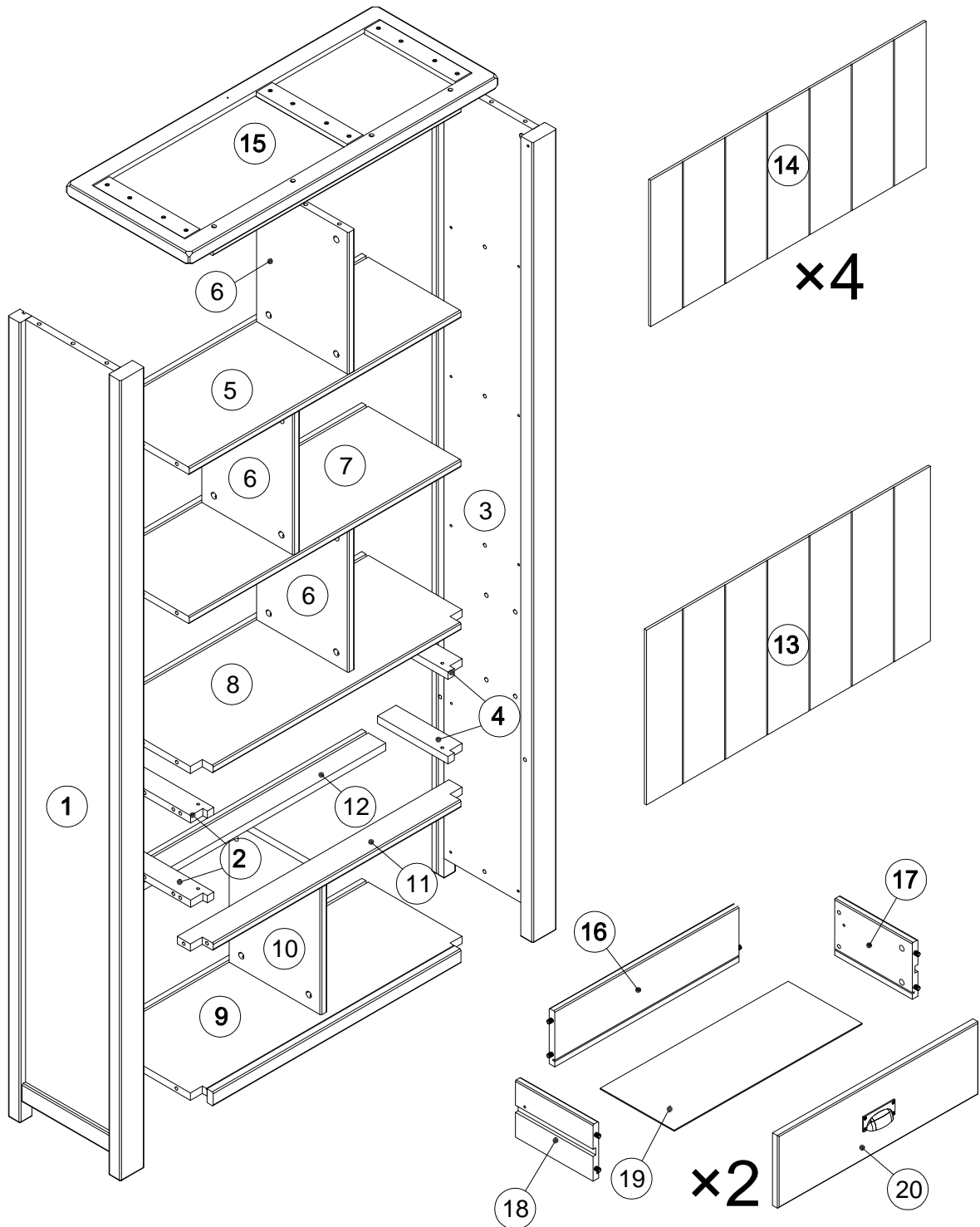

N KENDALL TALL SHELF

427377/975339
Assembly instructions

Components supplied. Please use this guide if you require replacement parts.

Ref	Dimensions	Visual	Qty	Ctn	Ref	Dimensions	Visual	Qty	Ctn
1	197.1 x 32cm		1	1	13	75.8 x 43cm		1	2
2	20 x 5.3cm		2	2	14	75.8 x 36cm		4	1
3	197.1 x 32cm		1	2	15	88 x 35cm		1	1
4	20 x 5.3cm		2	1	16	64.8 x 15.7cm		2	2
5	77.4 x 28.2cm		1	1	17	25 x 16cm		2	2
6	34.9 x 26cm		3	1	18	25 x 16cm		2	2
7	77.4 x 28.2cm		1	1	19	65.9 x 23.8cm		2	1
8	77.4 x 31.6cm		1	1	20	700 x 20.5cm		2	1
9	77.4 x 31.6cm		1	1					
10	34.9 x 26cm		1	1					
11	77.4 x 6.8cm		1	1					
12	77.4 x 6.8cm		1	1					

N KENDALL TALL SHELF

427377/975339

Assembly instructions

Fixtures and fittings supplied (actual size)

Ref	Dimensions	Qty	Spare
101	10×43.5mm	48	2
201	15×12mm	64	2
301	6×30mm	8	1
401	3.5×20mm	1	1
501	6×18mm	1	1

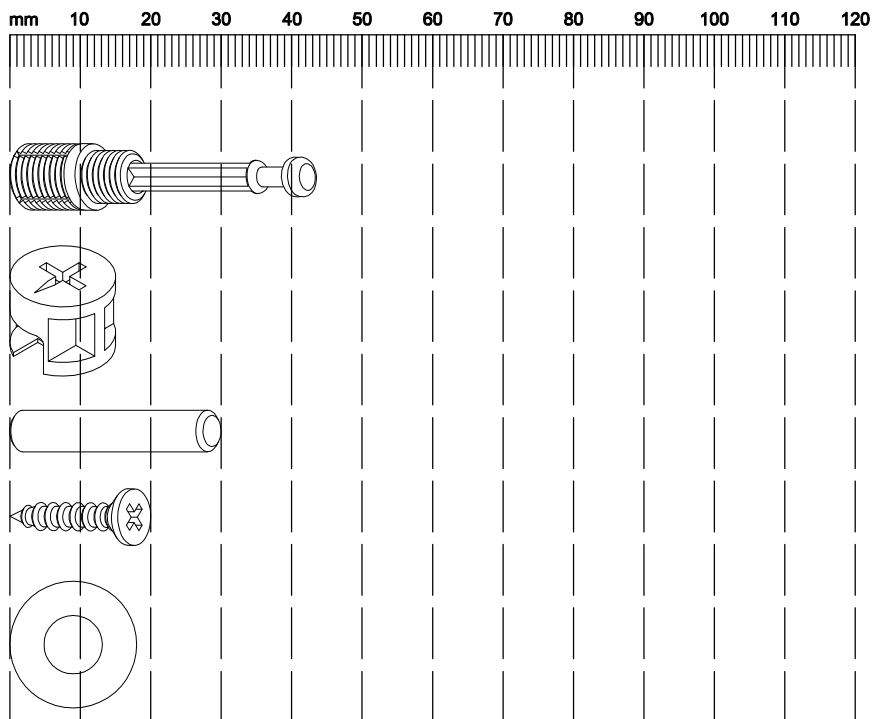

Fixtures and fittings supplied (not to scale)

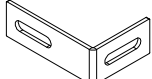



Ref	Dimensions	Visual	Qty	Spare Qty
601	N/A		1	0

N KENDALL TALL SHELF

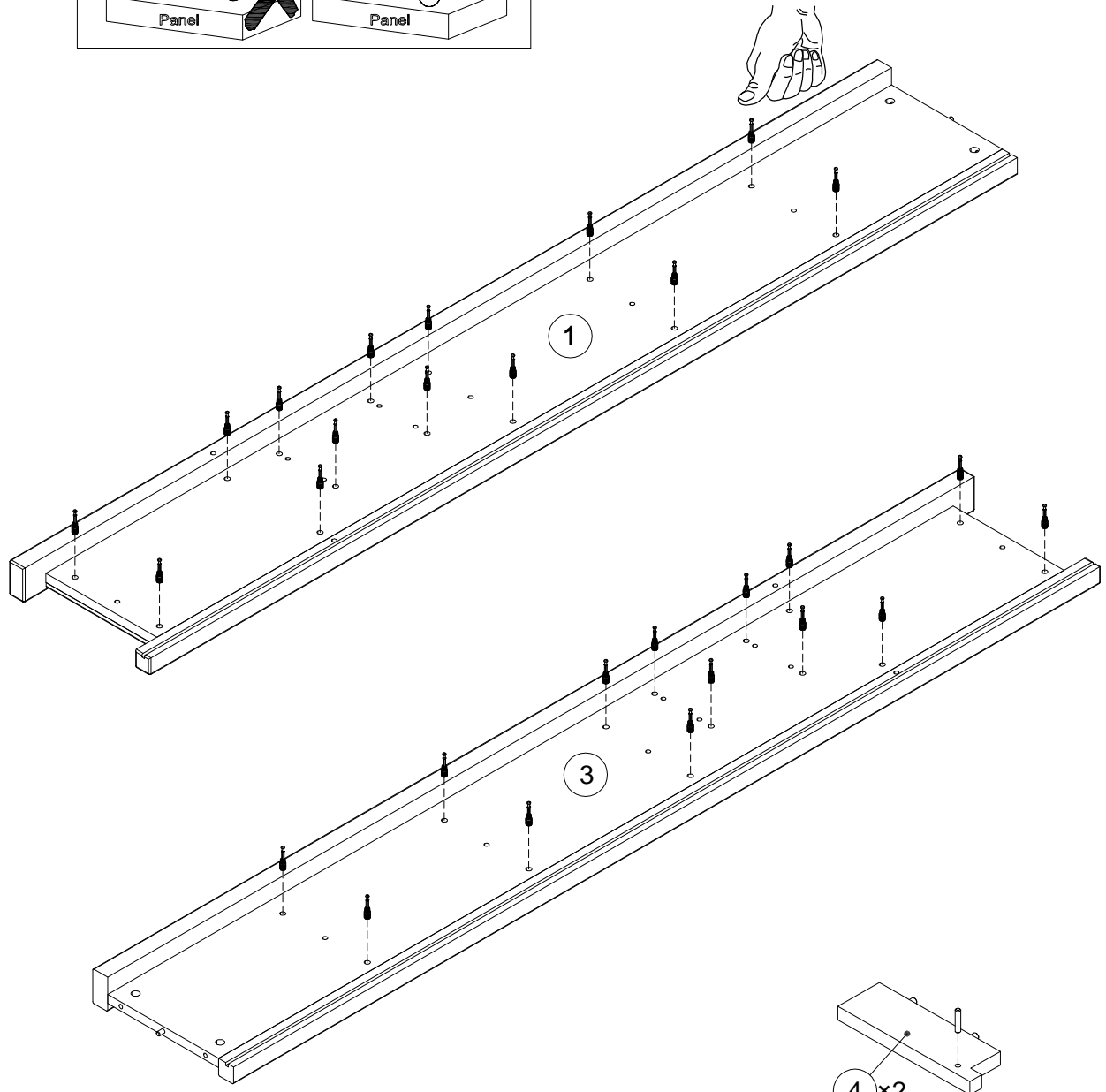
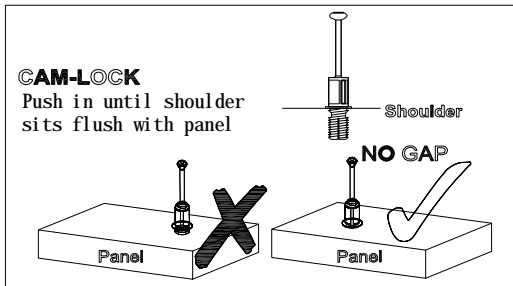
427377/975339
 Assembly instructions

1



	301x4 6x30mm
not supplied	
	101x28 10x43.5mm
	

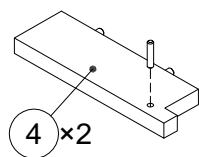
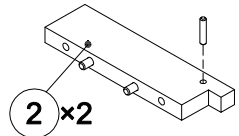

N KENDALL TALL SHELF

427377/975339
Assembly instructions

2

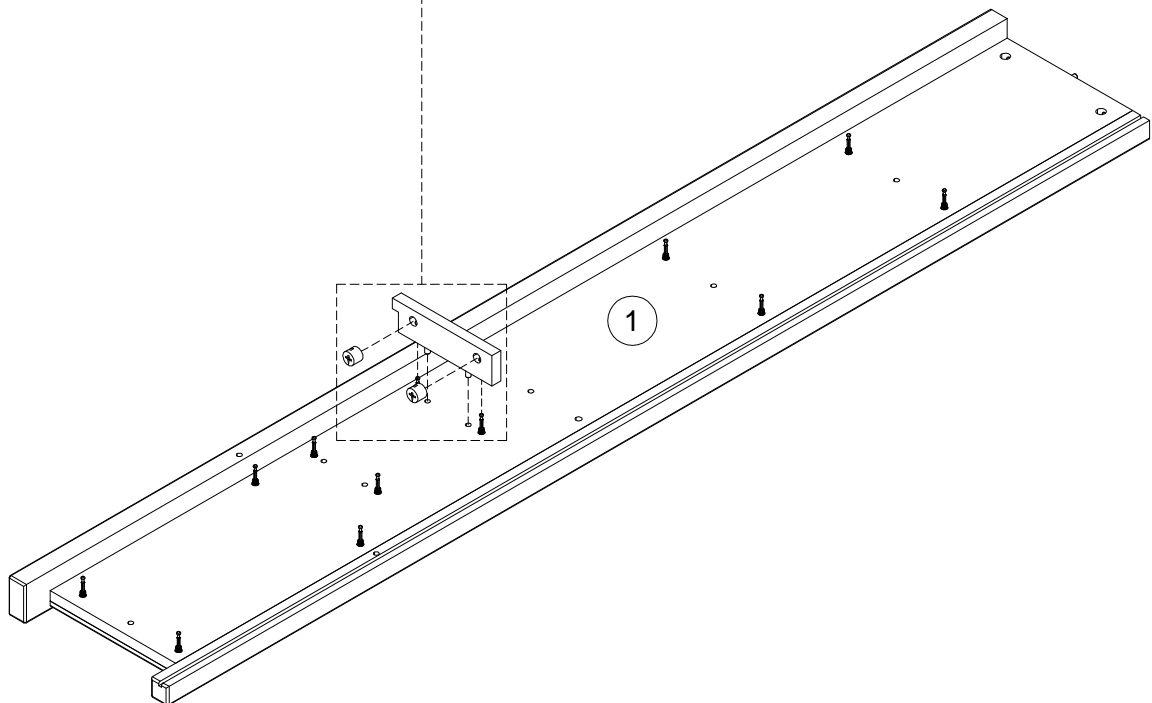
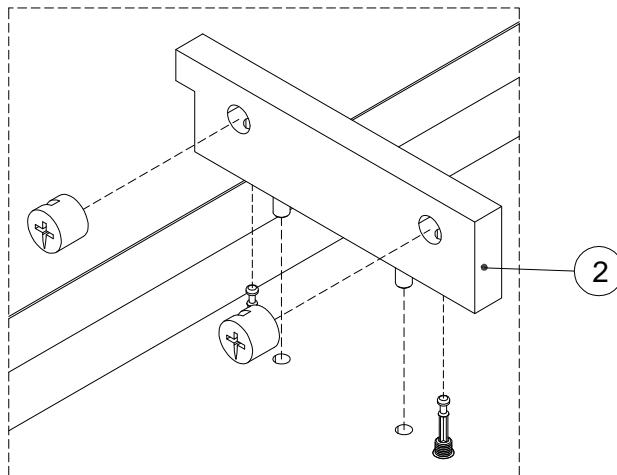

	201x2	15x12mm
		

N KENDALL TALL SHELF

427377/975339

Assembly instructions

3

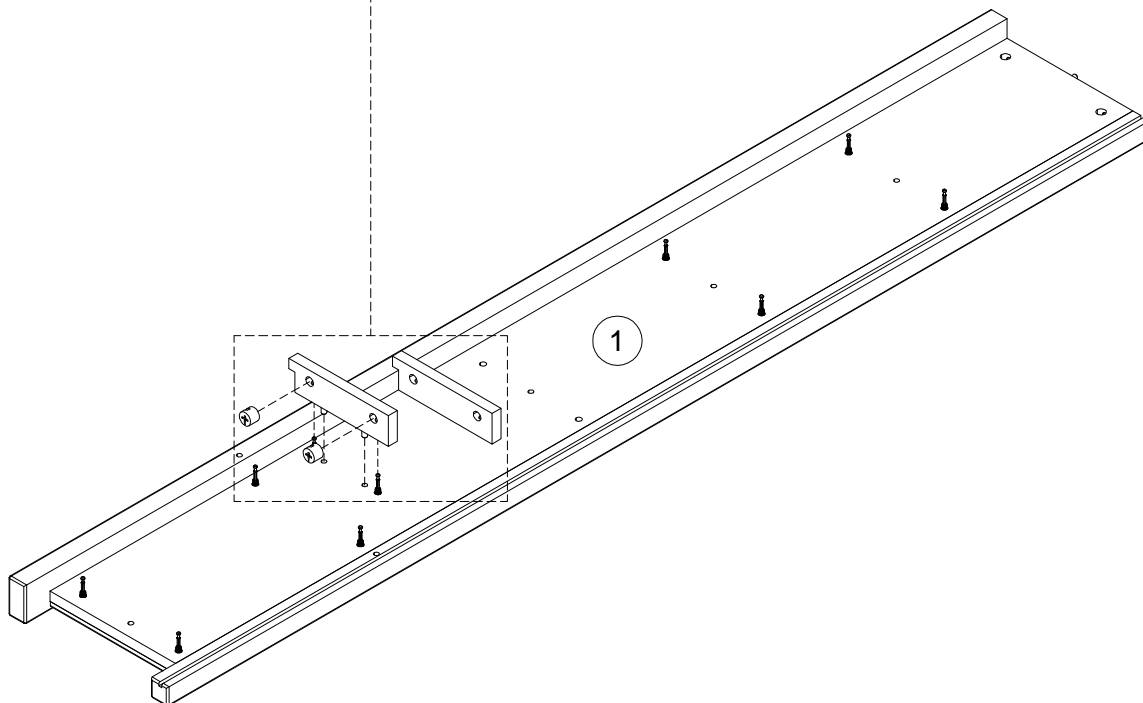
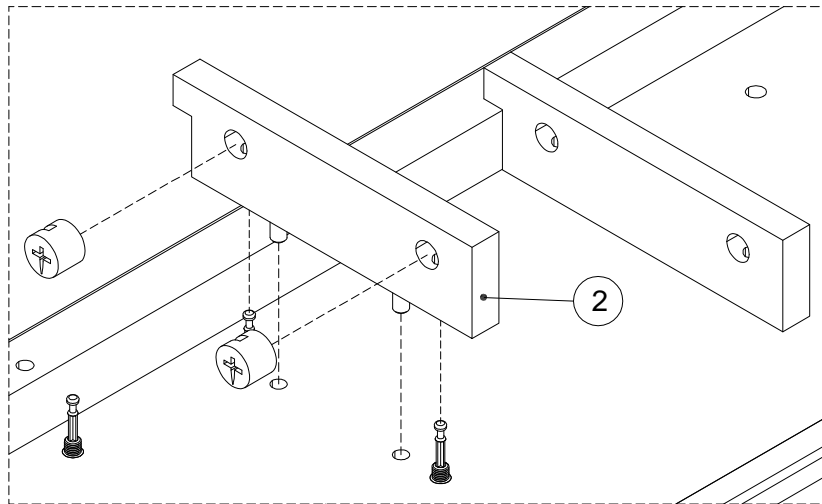

N KENDALL TALL SHELF

427377/975339
Assembly instructions

4

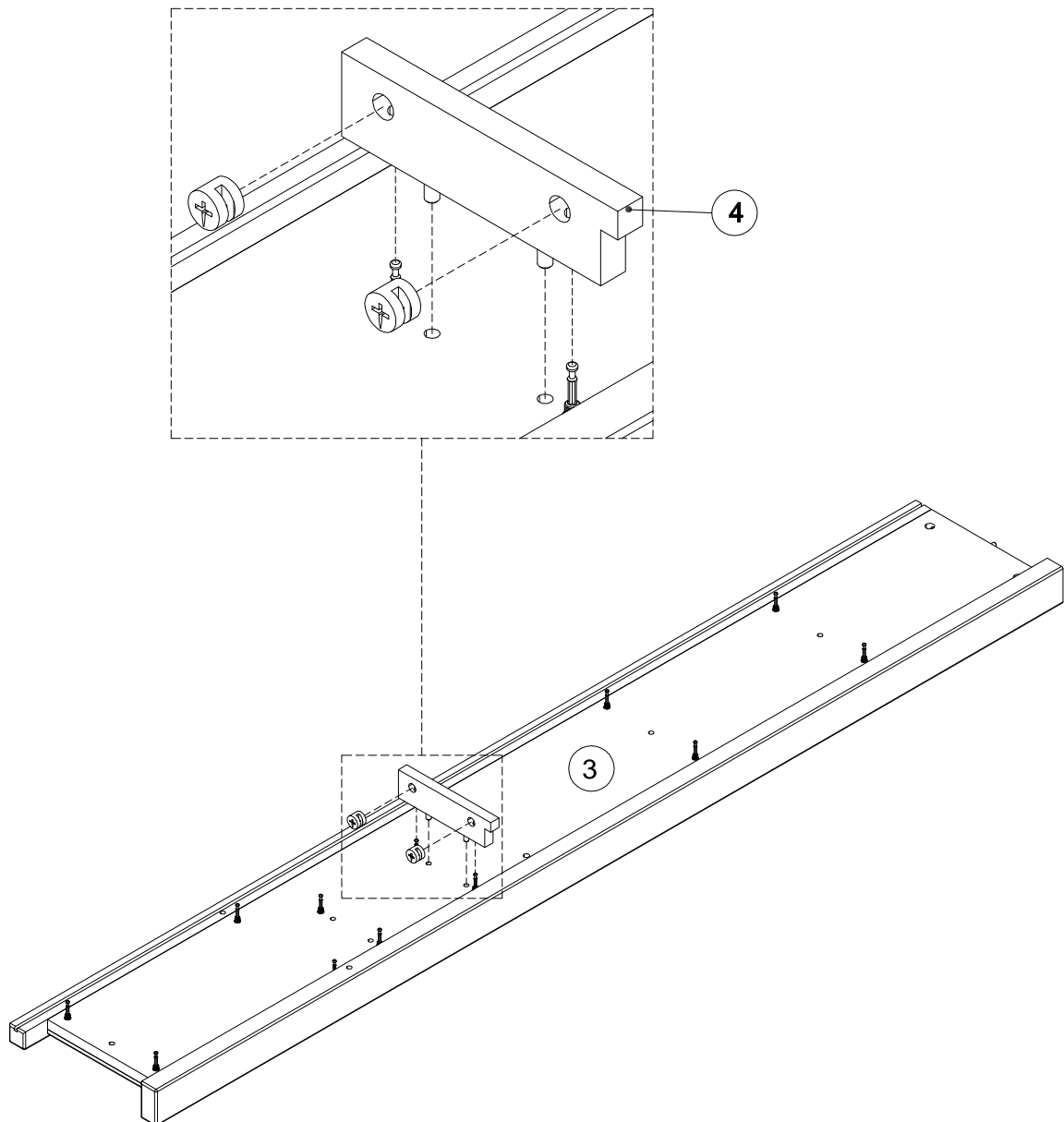

	201x2	15x12mm
		

5

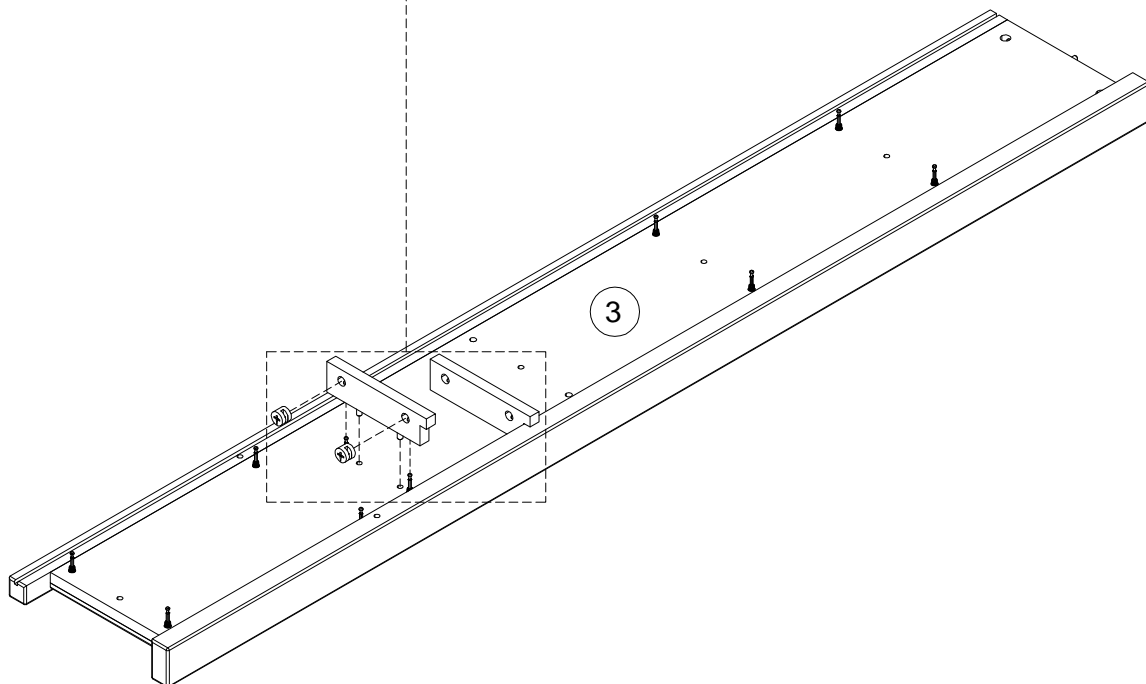
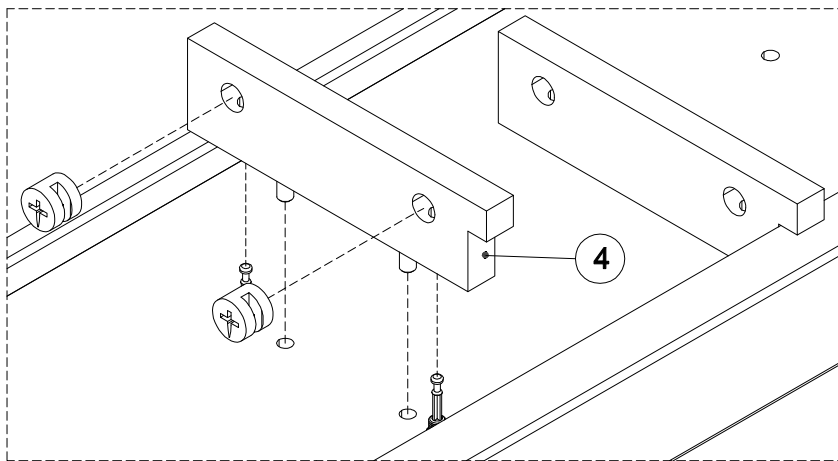

N KENDALL TALL SHELF

427377/975339
 Assembly instructions

6

501×1

401×1 3.5×20mm
 PH2
 not supplied

101×6 10×43.5mm

601×1

7

101×4 10×43.5mm

N KENDALL TALL SHELF

427377/975339
Assembly instructions

8

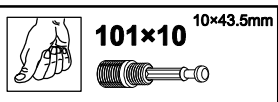
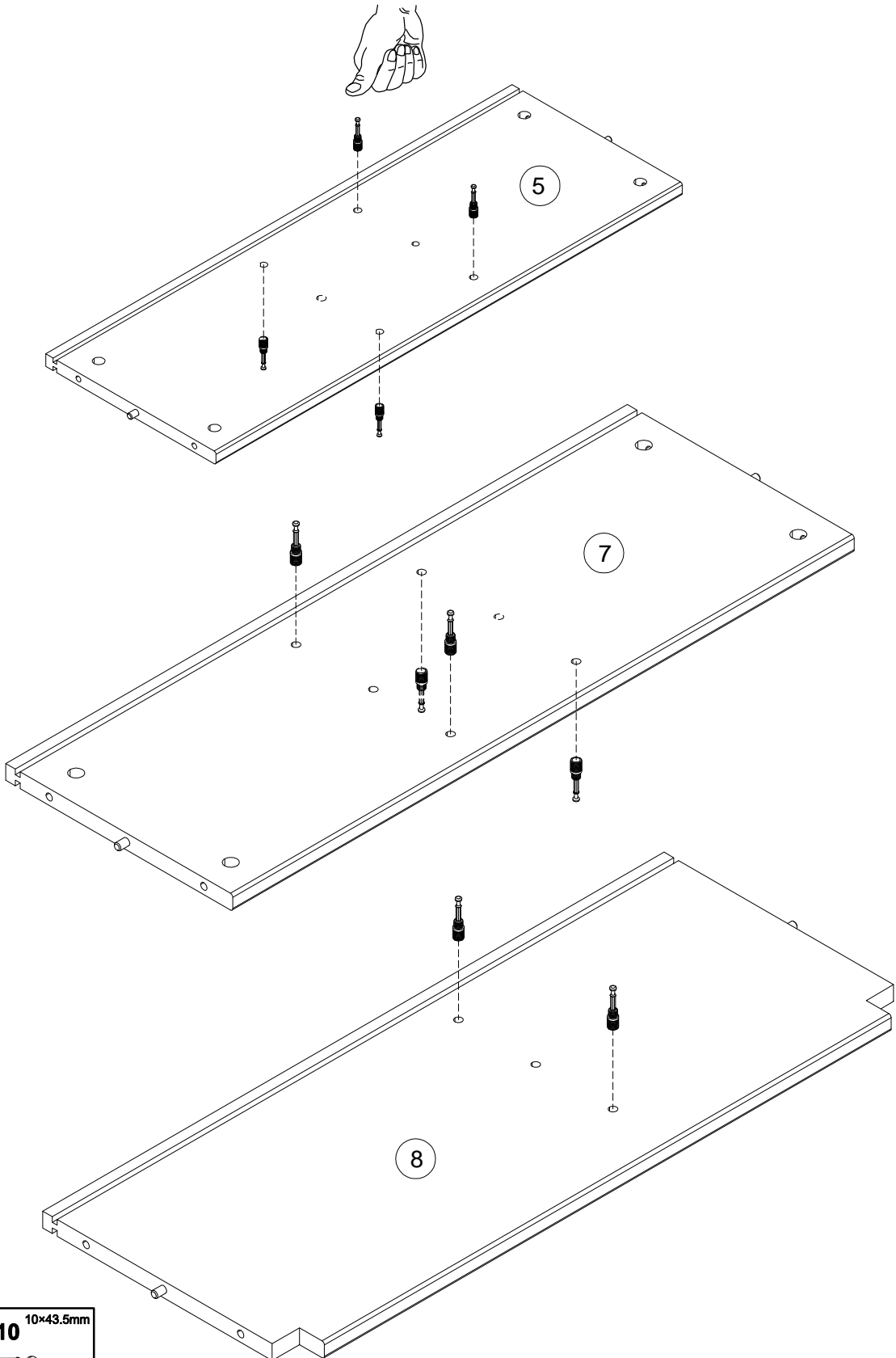

N KENDALL TALL SHELF

427377/975339
Assembly instructions

9

DON'T STOP UNTIL THE 2 O'CLOCK LOCK
TURN THE CAM IN A CLOCKWISE DIRECTION UNTIL THE
ARROW POINTS IN THE POSITIONS SHOWN IN THE
DIAGRAMS BELOW

START CORRECT LOCK

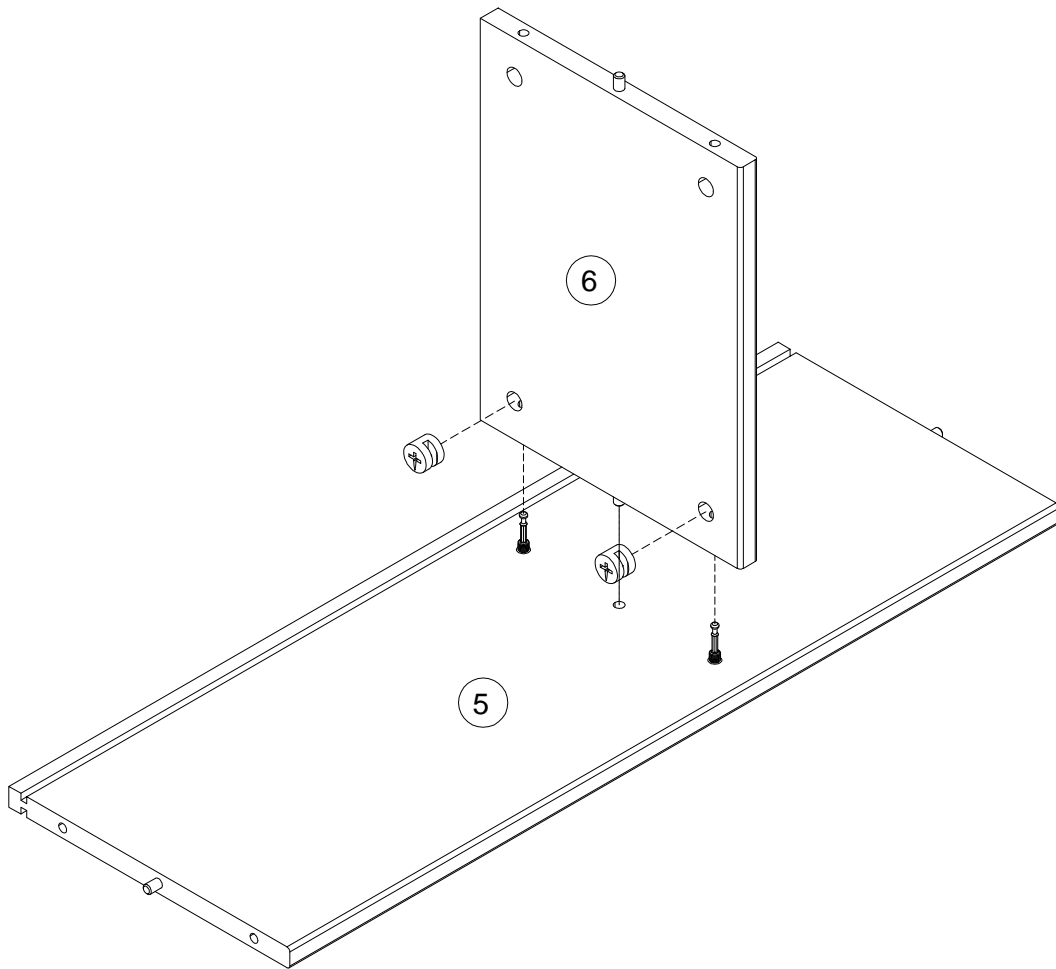

PH2 **201x2** 15x12mm
not supplied

10

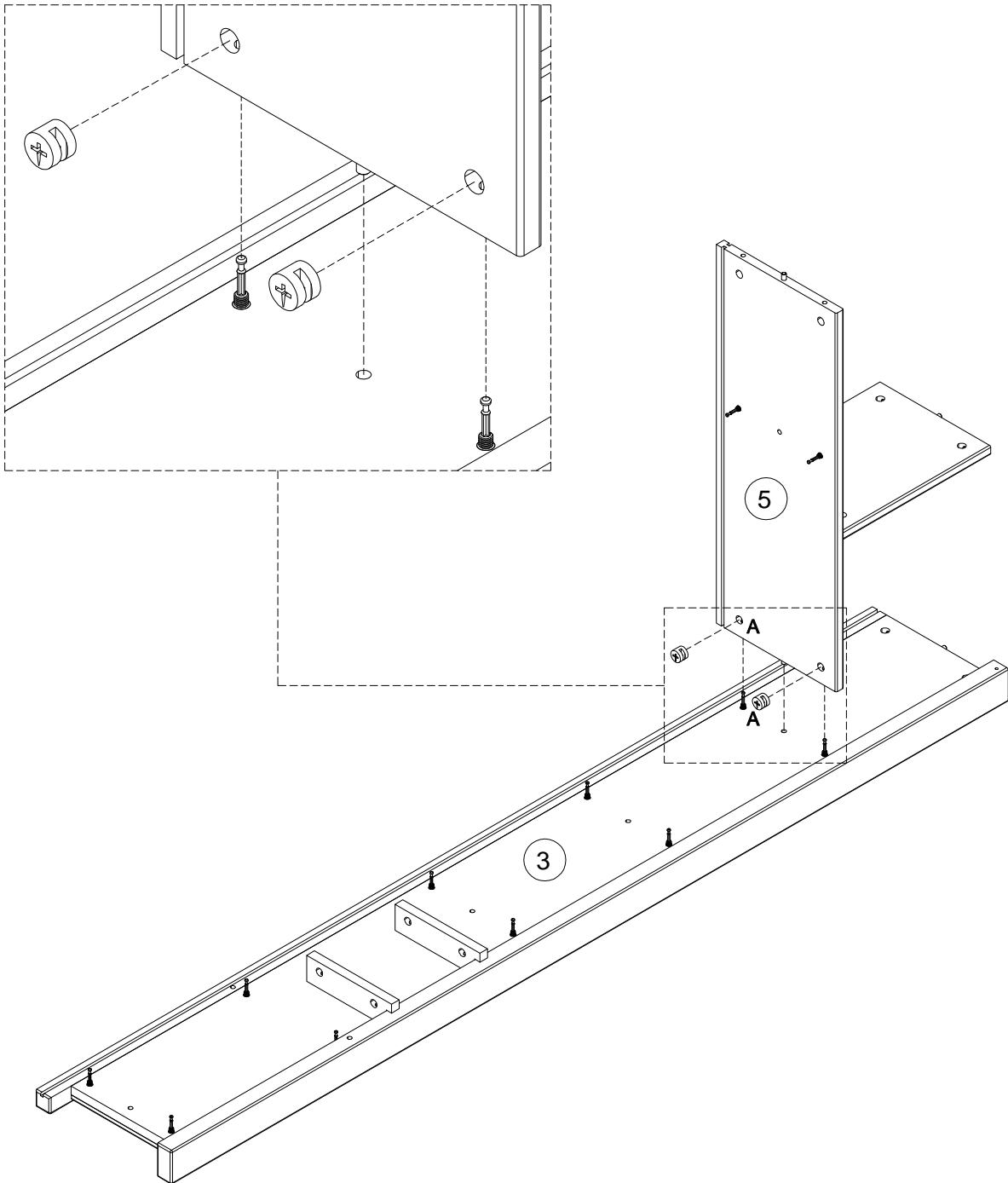

PH2 201x2 15x12mm
not supplied

11

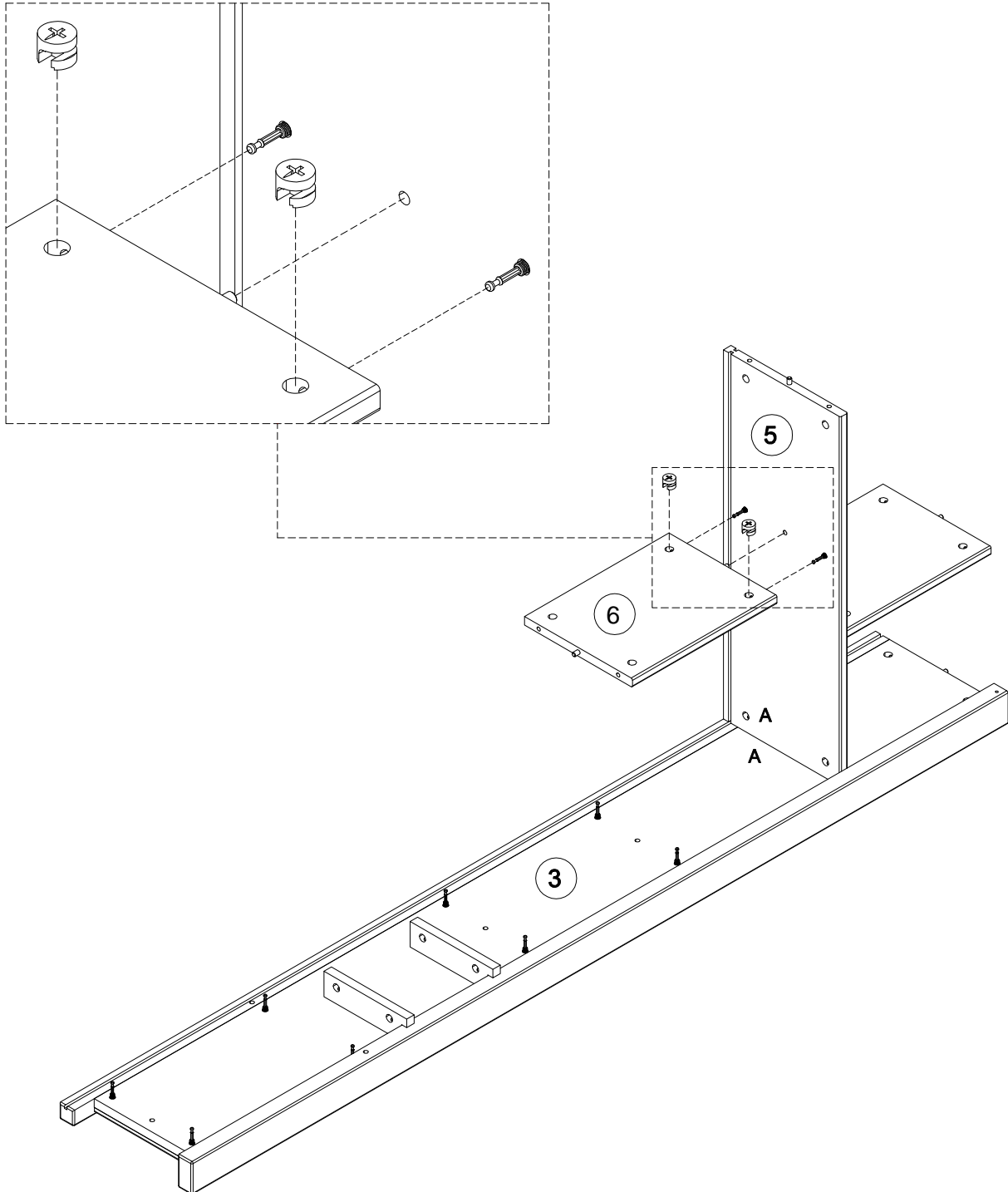

12

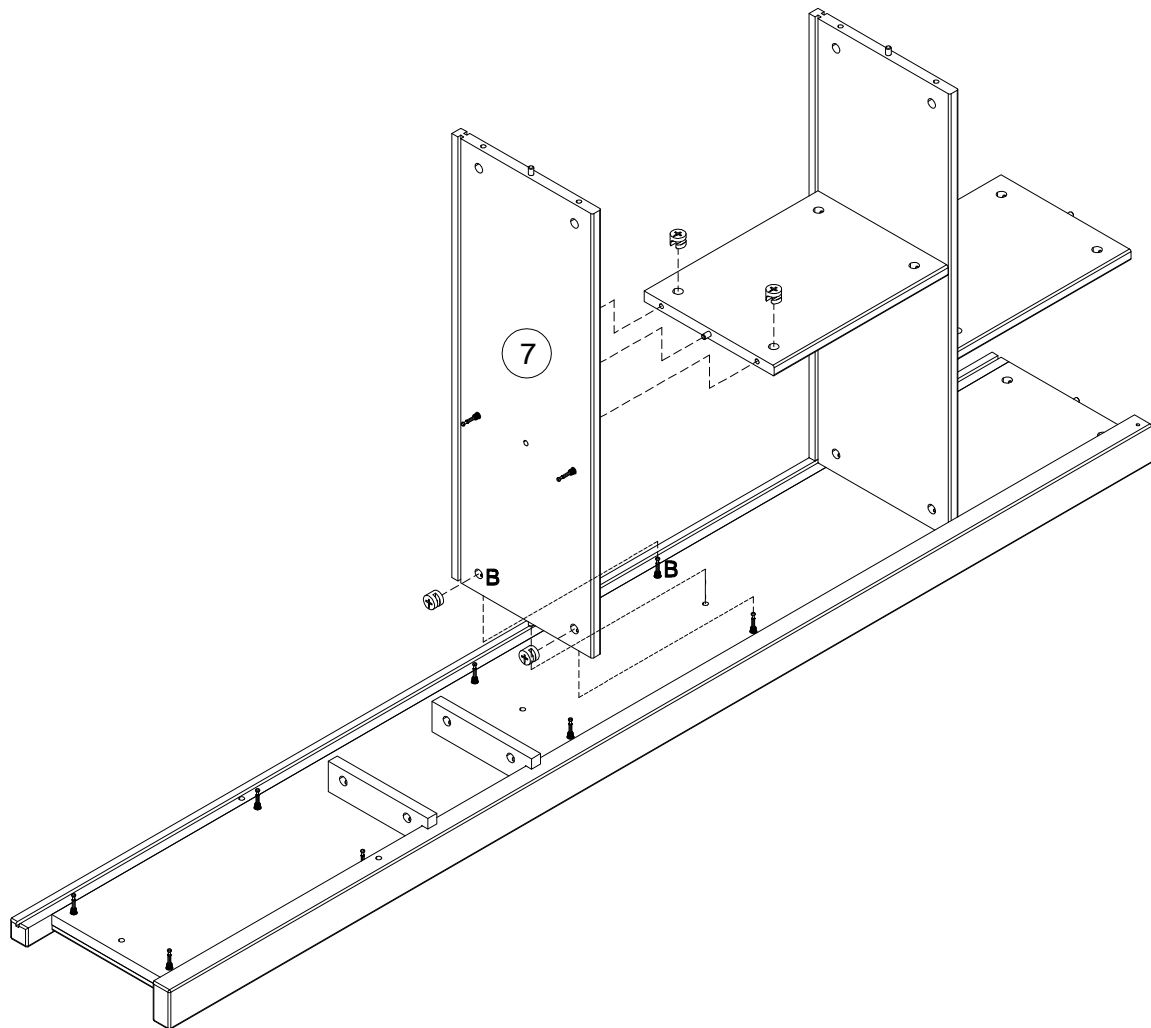

	201x4	15x12mm
		

13

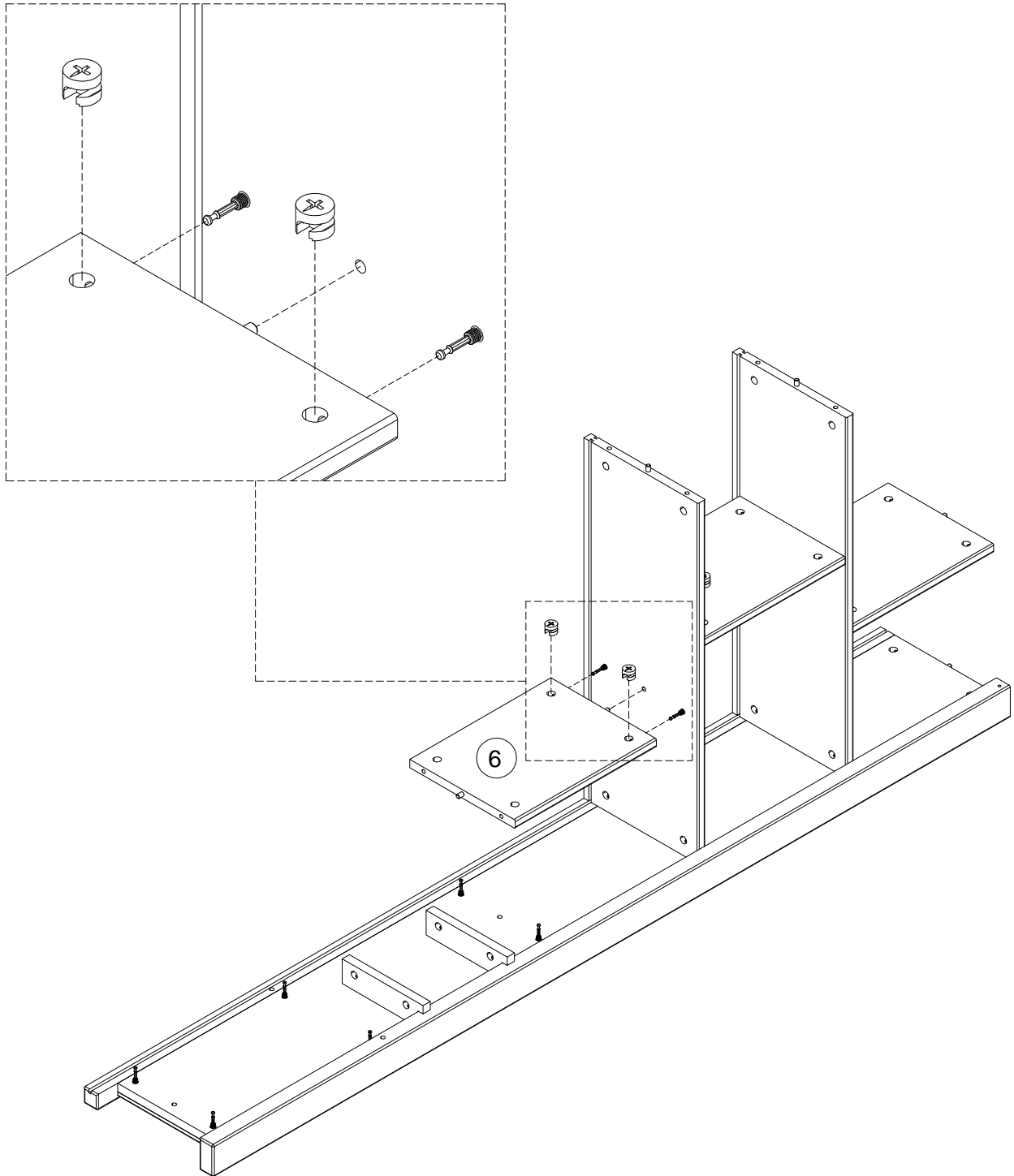

 **201x2** 15x12mm
 not supplied 

14

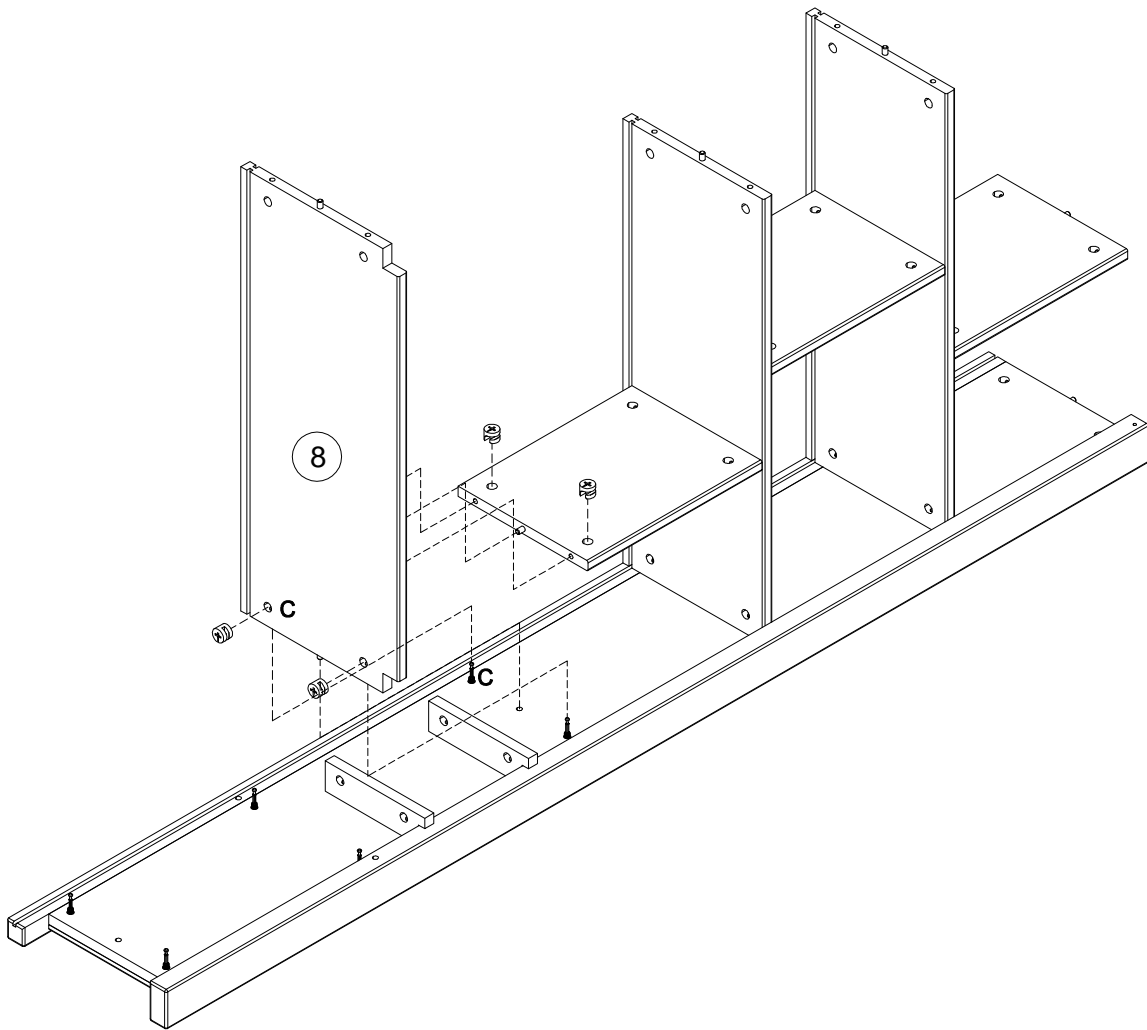

	201x4	15x12mm
		

15

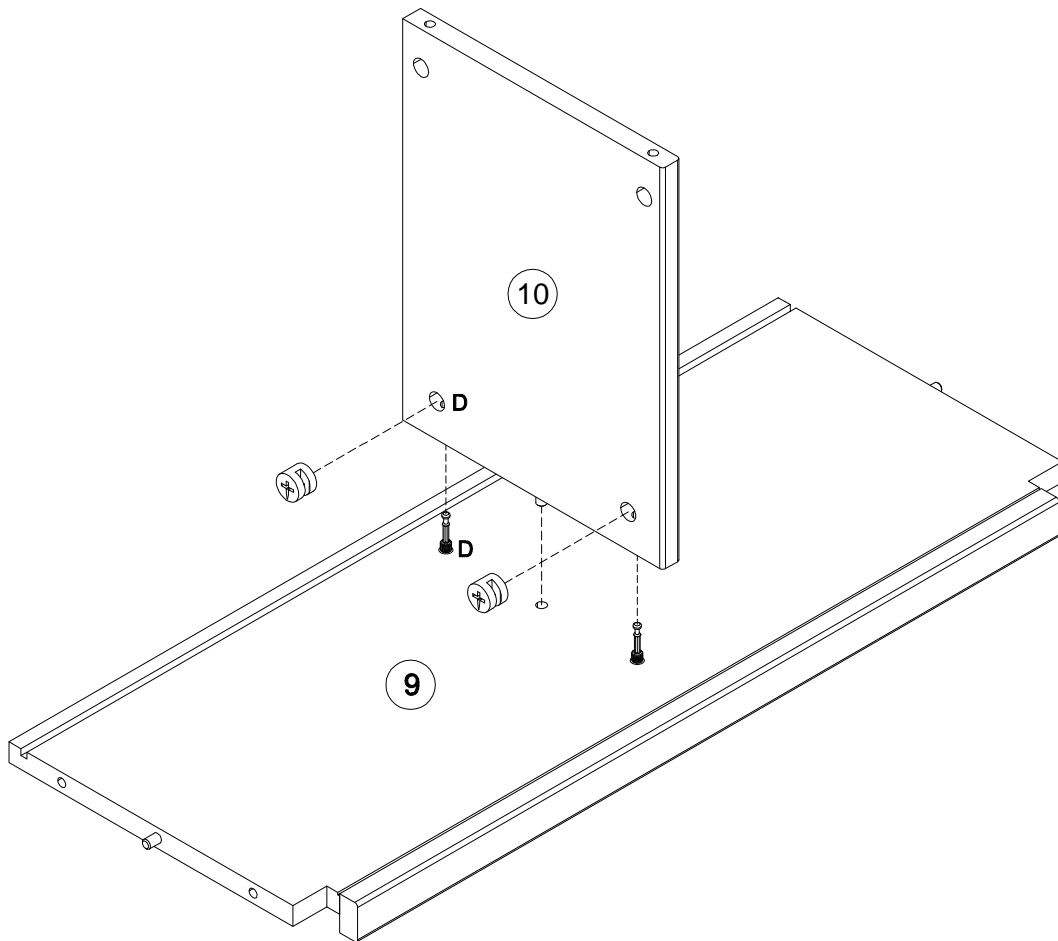

 not supplied	201x2	15x12mm
---	--------------	---------

16

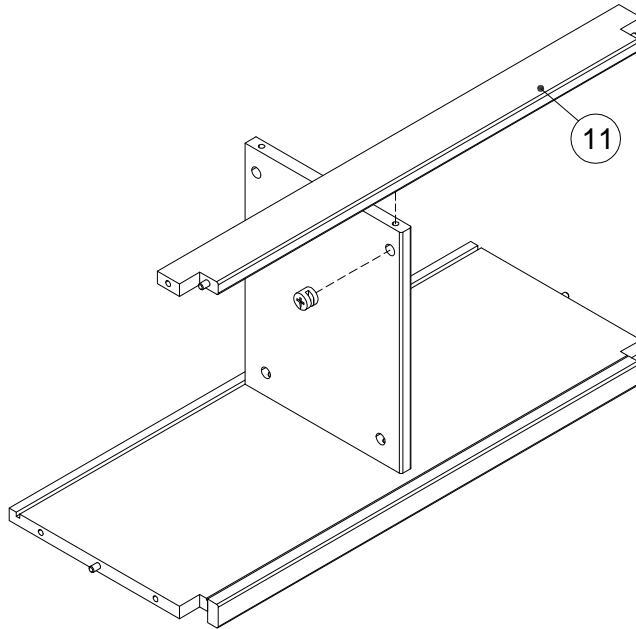

PH2
not supplied

201x1 15x12mm

17

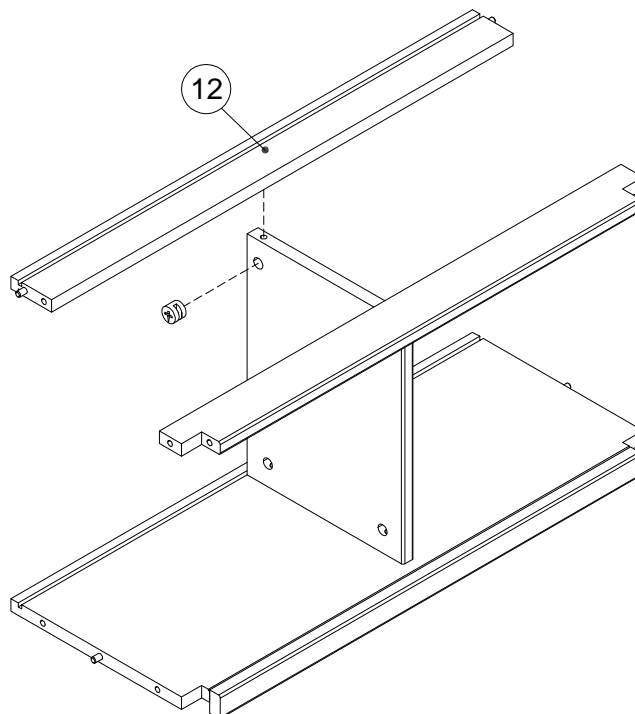

PH2
not supplied

201x1 15x12mm

N KENDALL TALL SHELF

427377/975339

Assembly instructions

18

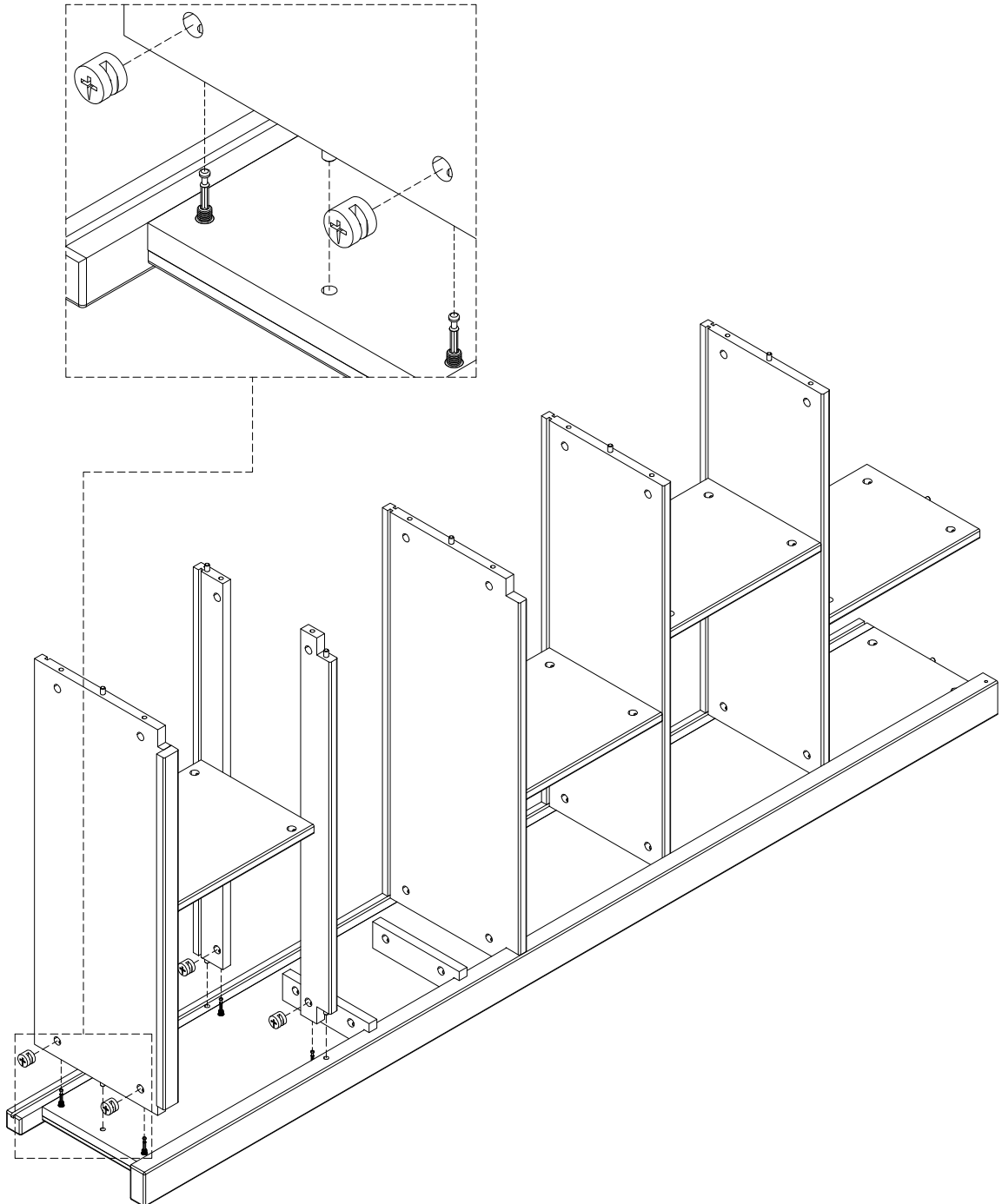

PH2 201x4 15x12mm
not supplied

19

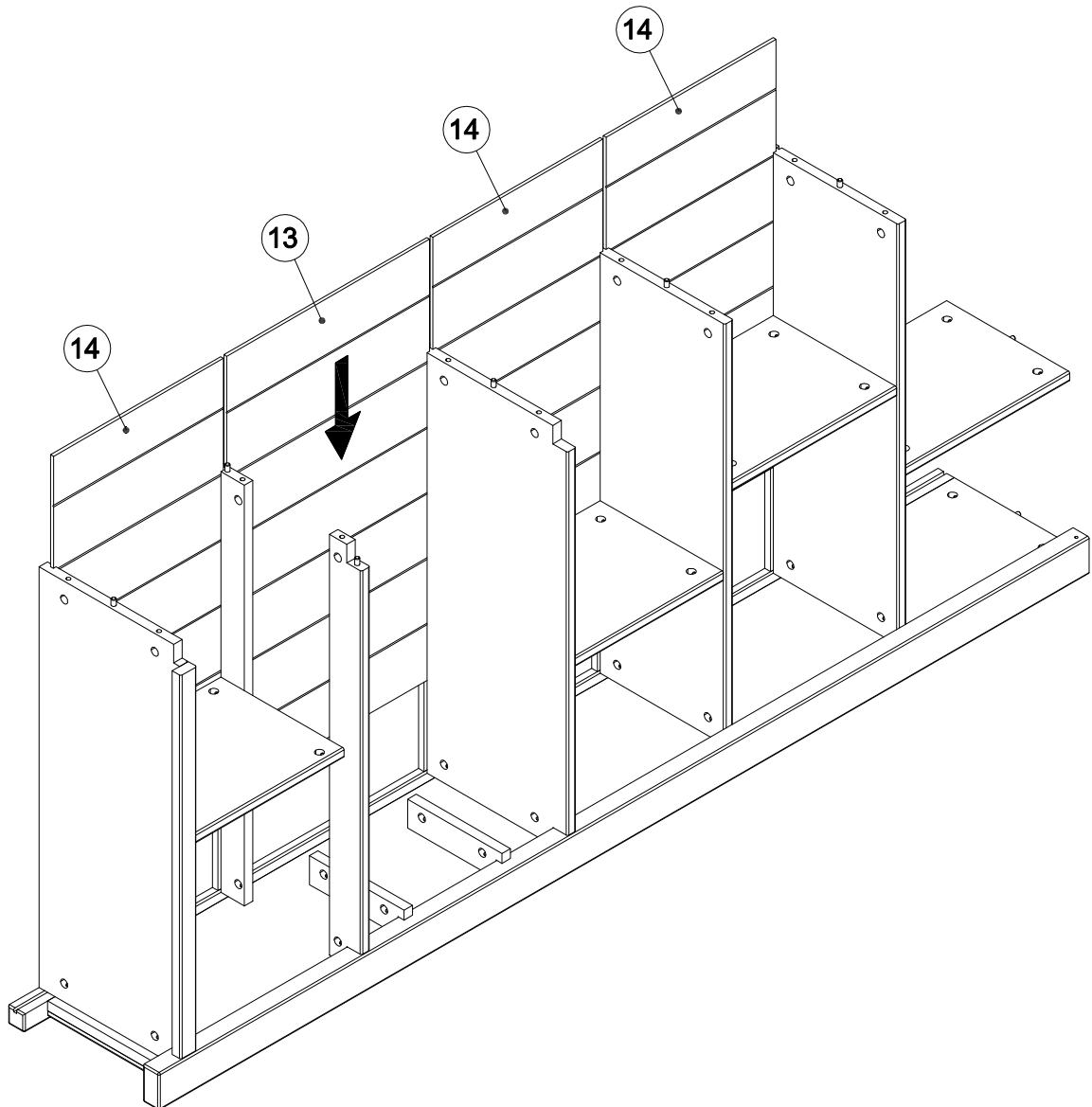

N KENDALL TALL SHELF

427377/975339

Assembly instructions

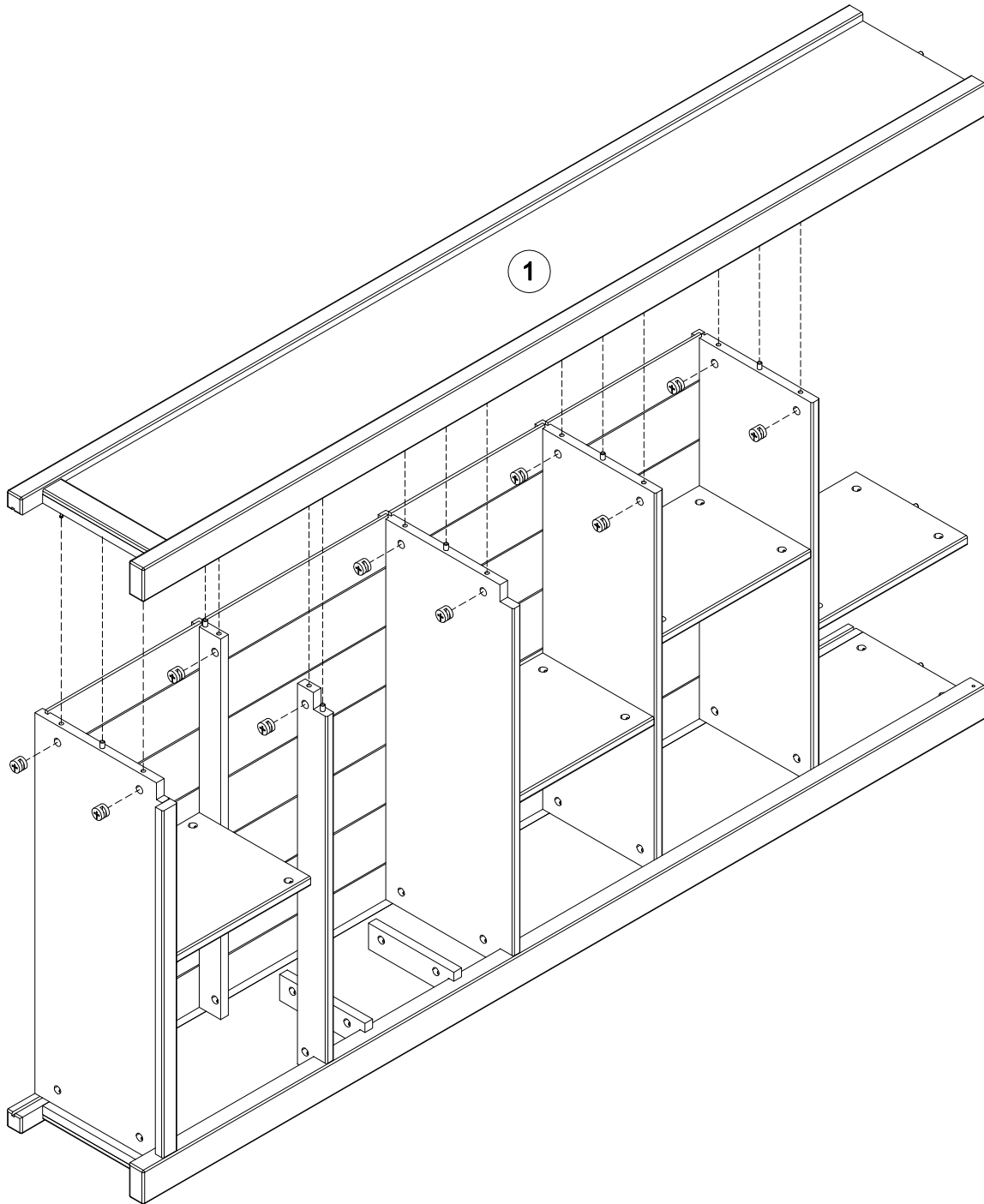

PH2 **201x10** 15x12mm
not supplied

21

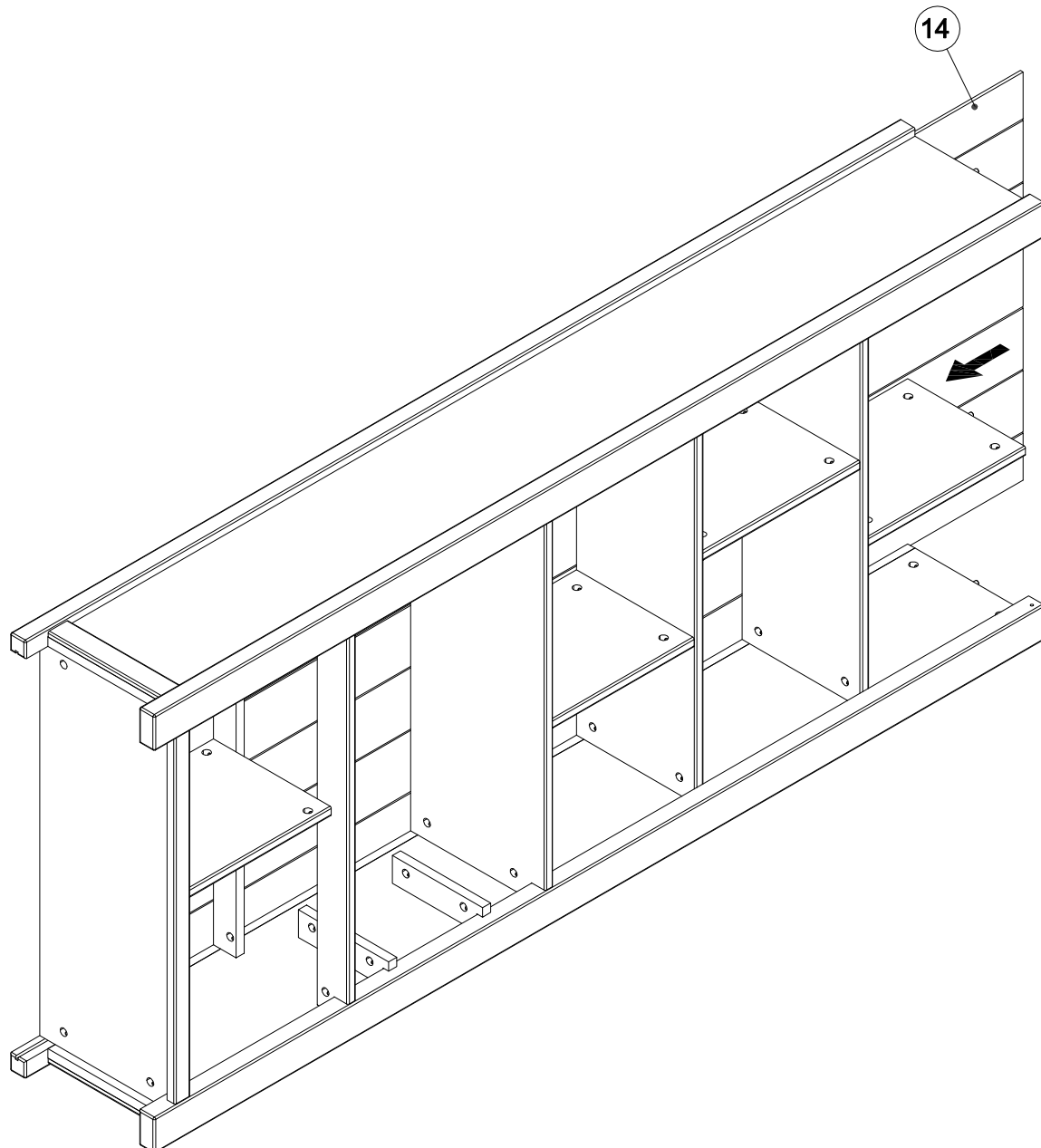

N KENDALL TALL SHELF

427377/975339

Assembly instructions

22

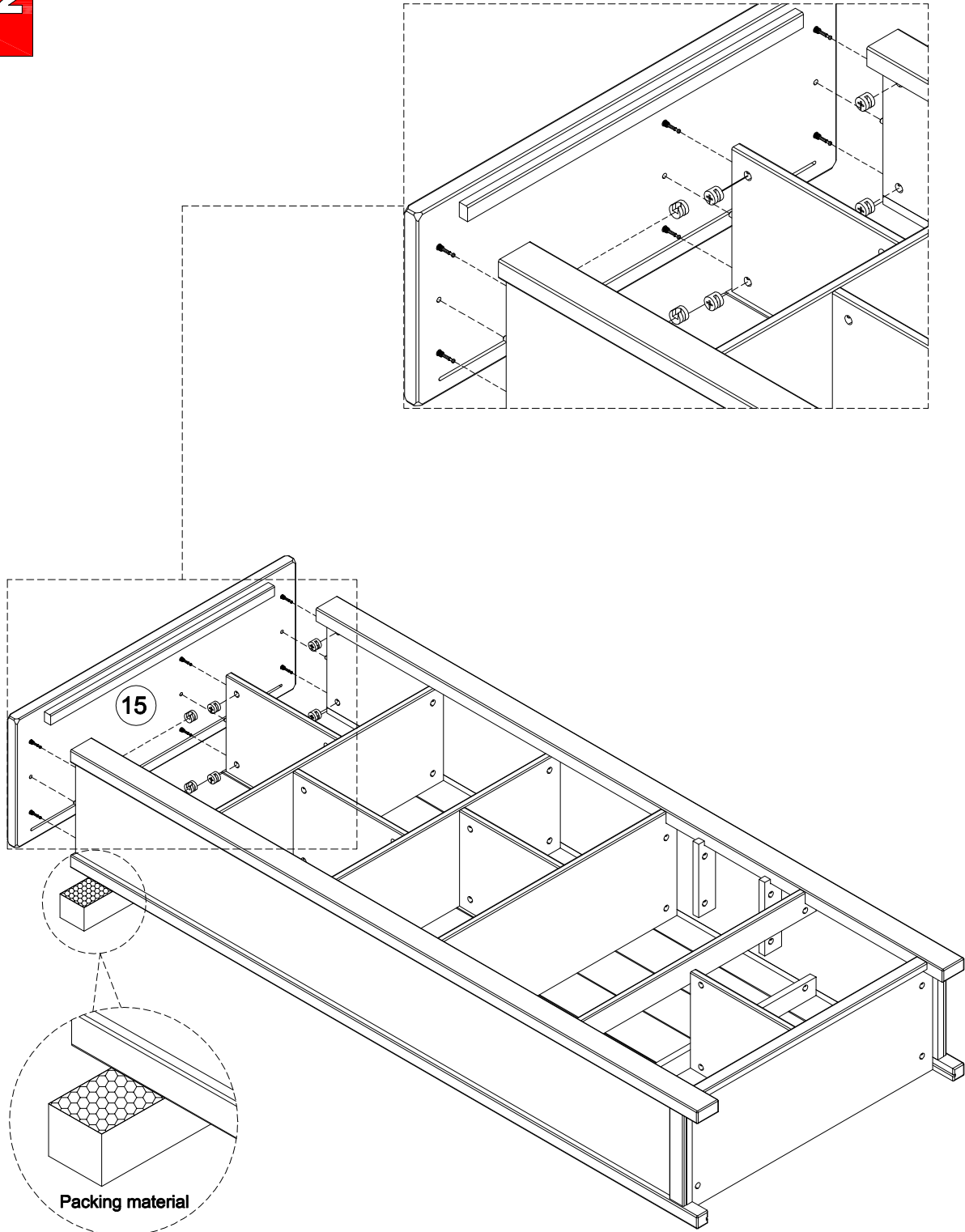

PH2 201x6 15x12mm
not supplied

N KENDALL TALL SHELF

427377/975339
Assembly instructions

23

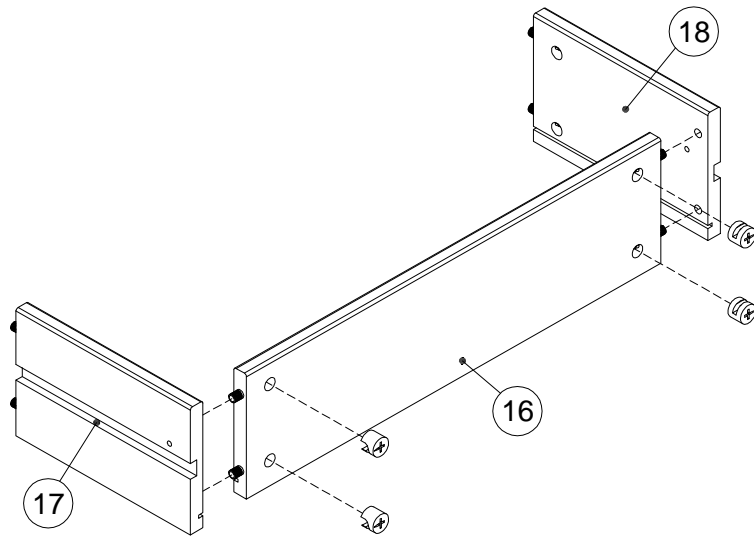

X2

24

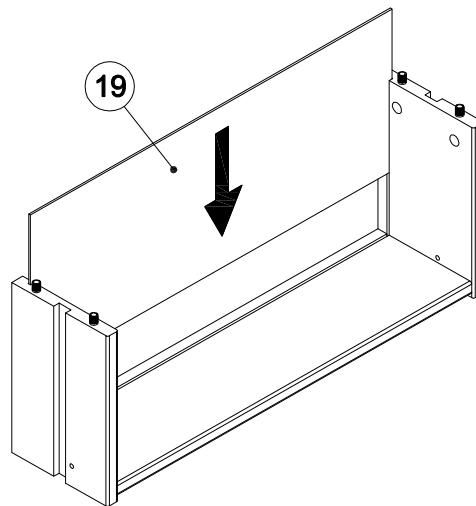

X2

25

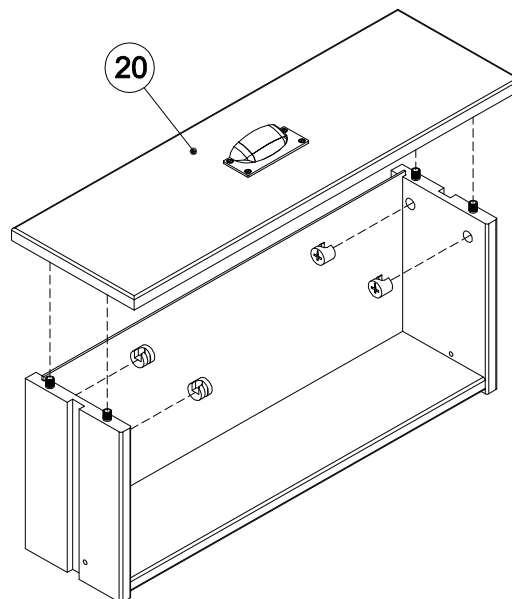

X2

PH2
not supplied
201 x 8
15x12mm

PH2
not supplied
201 x 8
15x12mm

N KENDALL TALL SHELF

427377/975339
Assembly instructions

26

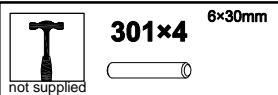
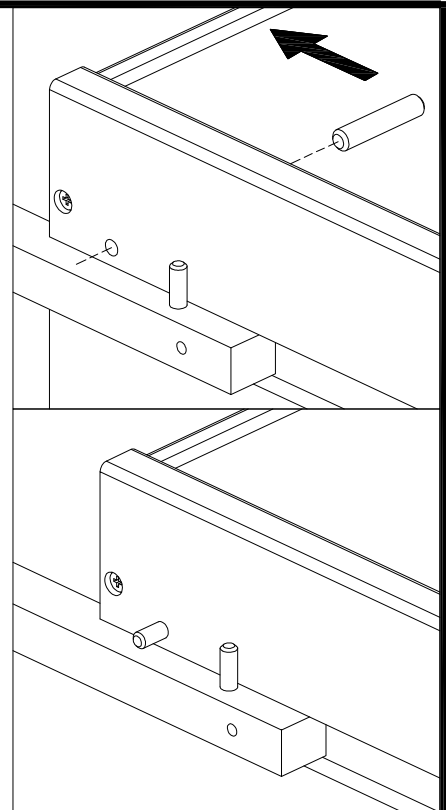
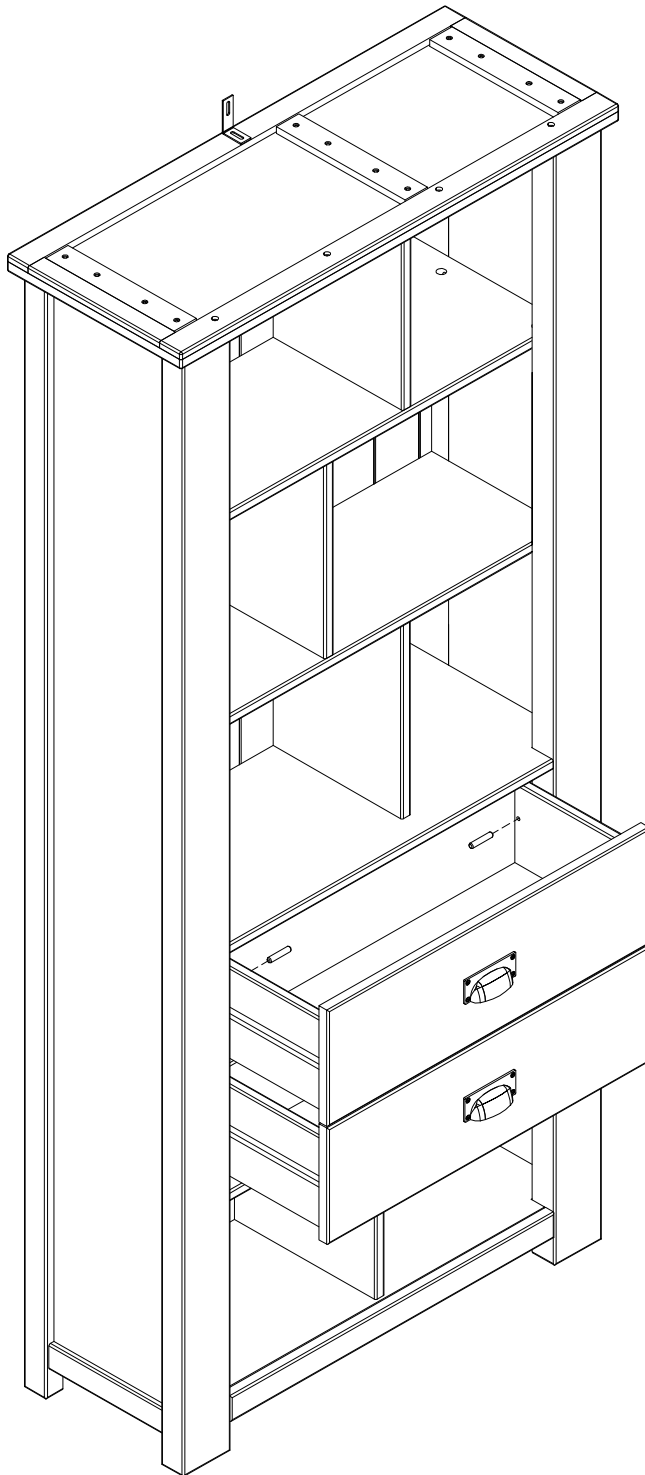

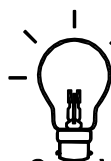
27

1. Move the item into position and attach the end of the strap to the wall with the appropriate screw, washer and wall plug for your wall type .
2. **WARNING:** Always ensure the area to be drilled is free from hidden electrical wires, water and gas pipes.
3. **NOTE:** Wall fixings are not included , please source suitable fixings for your wall type, if in doubt, please consult a qualified tradesman.

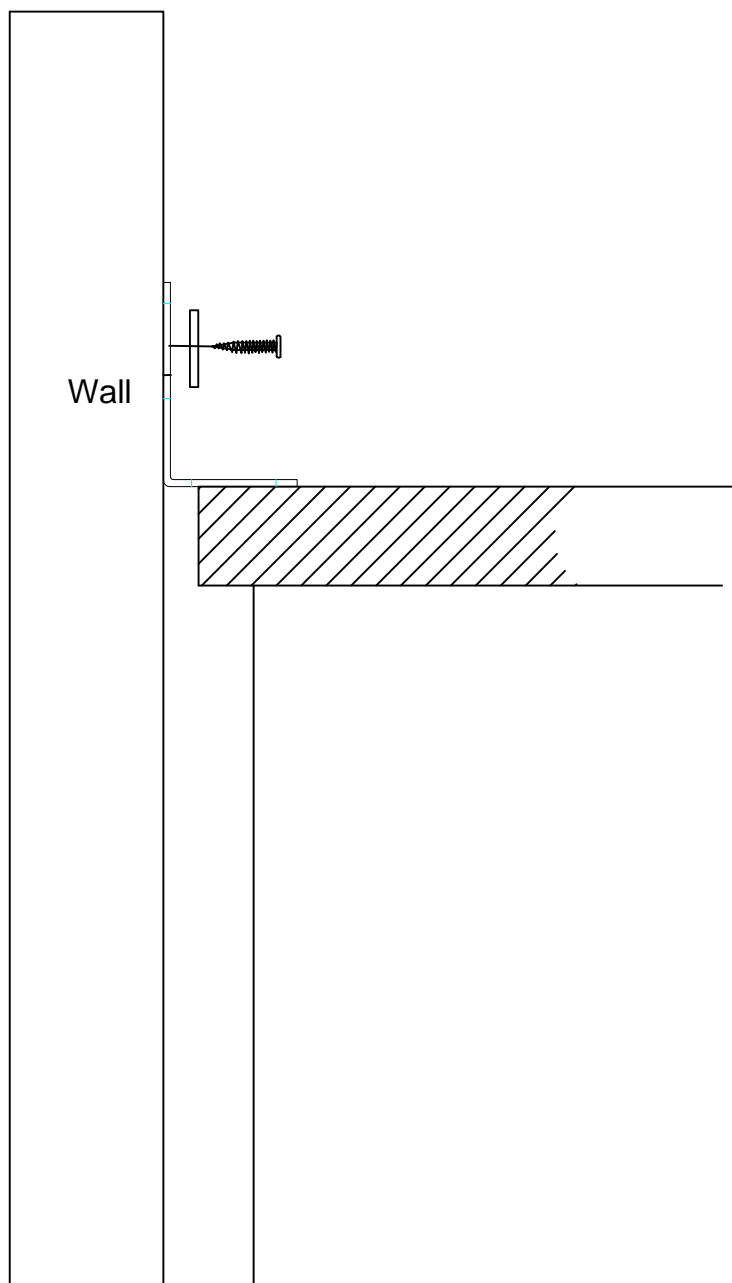

next

N KENDALL TALL SHELF

427377/975339

Assembly instructions

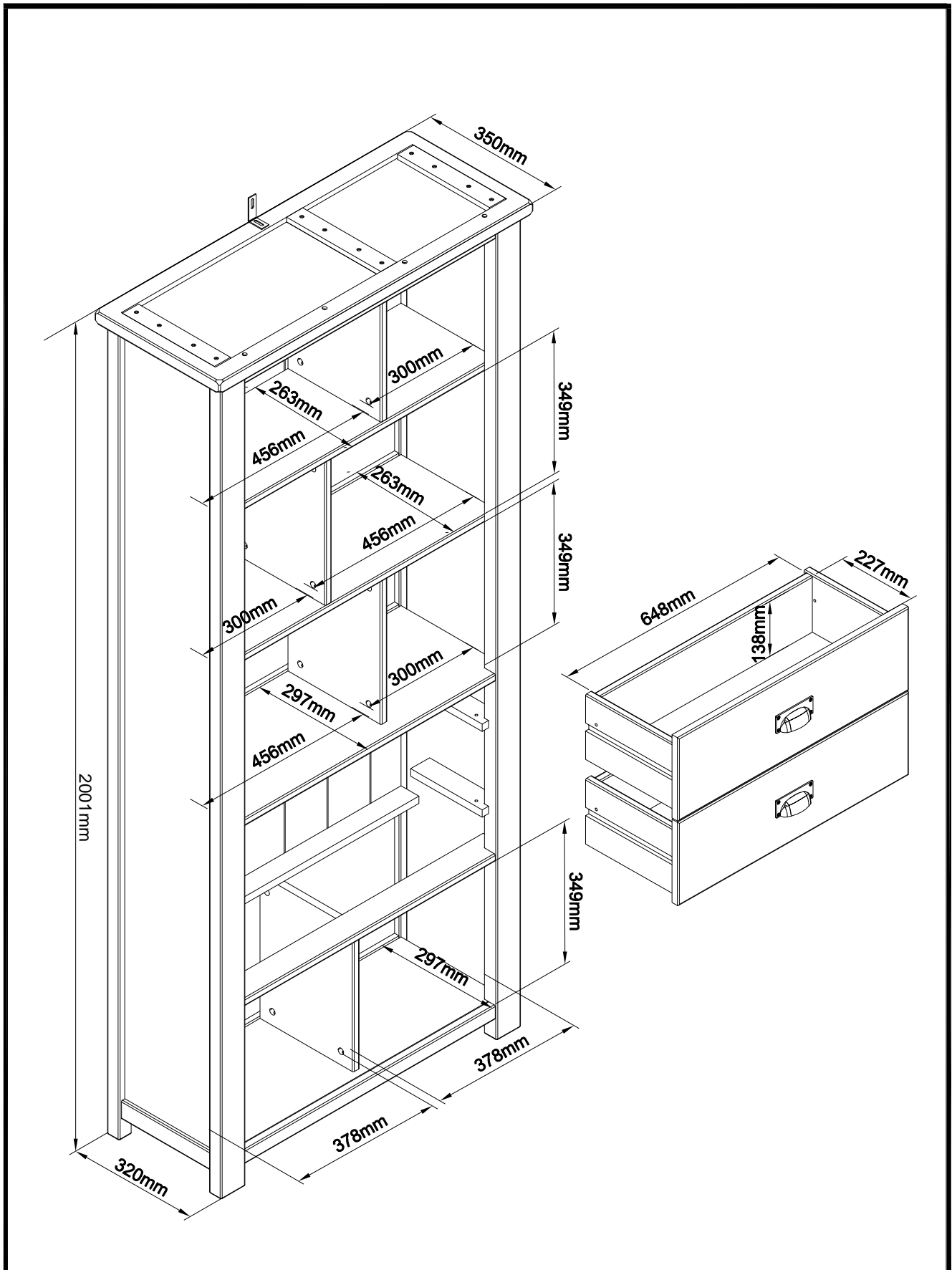

next

Assembly instructions

Warnings

We suggest you retain these instructions for future reference.

Keep fittings out of children's reach and keep children well away from the construction area.

This product should only be used on firm, level ground.

Please periodically check all fittings and re-tighten as necessary.

Please do not sit or stand on your furniture.

Avoid exposing the furniture to excessive heat or direct sunlight as this can cause deterioration of the colour.

Unwrap all packaging materials and place the components on top of the carton box or on a clean floor to protect it from damage.

Missing parts

If you are missing any fixtures and fittings for your product please contact our customer service team on **0333 777 8999** and they will be happy to arrange for a replacement to be sent to you free of charge.

Home service technicians

If you have a fault with your product please contact our customer service team on **0333 777 8999**. If you have had the product for 28 days or less you may be offered a replacement, refund or for a fully trained home service technician to visit your home to assess the fault and repair the product where possible. If you have had the product for more than 28 days we will send an independent home service technician to review and repair the product where possible and recommend further action.

You can write to us at

Home Customer Services

Next Retail Ltd,
Desford Road,
Leicester,
LE19 4AT

To view our full furniture range please visit www.next.co.uk

PRODUCT SUPPLIED WITH WALL FIXING BRACKET