

ASSEMBLY INSTRUCTIONS.**IMPORTANT - RETAIN FOR FUTURE REFERENCE - READ CAREFULLY.****Tools Needed****Helpline**

If you have any problems with this product or require any replacement fittings please contact Customer Services Tel: 0333 777 8999

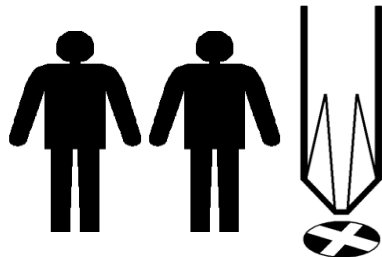
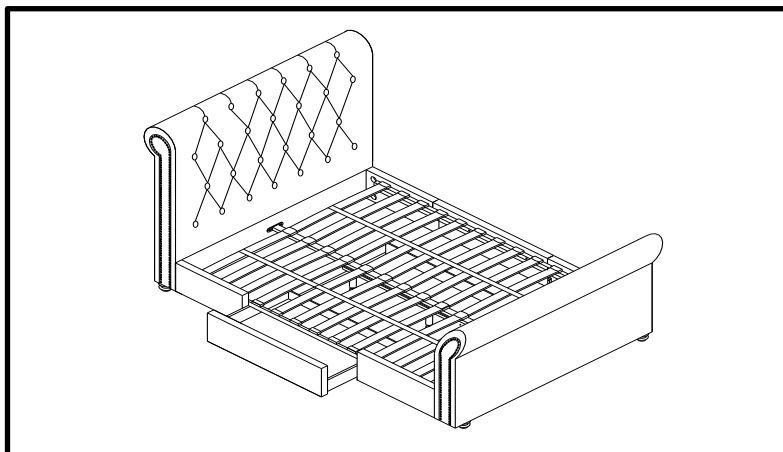

Regrettably self assembly items cannot be returned once assembly is part or fully completed unless the item is found to be faulty. Should you need to return the unassembled product, please repack in the original packaging.

IMPORTANT

- We suggest you spend a short time reading through this leaflet and then follow the simple step-by-step instructions.
- Carefully check that you have all the parts before beginning assembly.
- Keep fittings out of children's reach and keep children well away from construction area.
- A minimum of 2 persons is required to assemble this product.
- We recommend that the packaging is used to protect the surfaces during assembly.









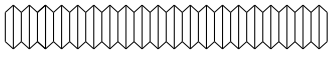
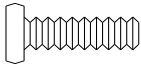
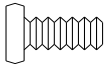
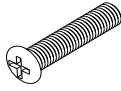

PRODUCT INFORMATION

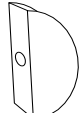
- Fabric content - 50% Cotton, 50% Polyester.
- Foam is supplied to protect the front face. Do use the foam to protect the main face during assembly.
- Made in China.

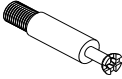





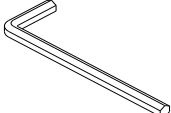
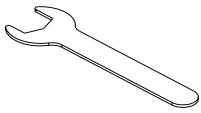

CARE INSTRUCTIONS

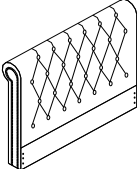
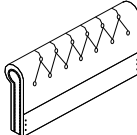
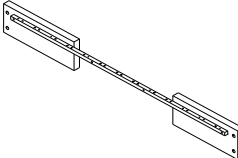
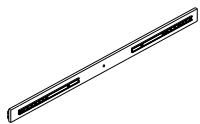
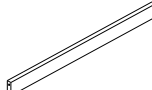
- Hair products such as hairsprays, oils and gels may affect the finish. Avoid prolonged contact with such products.
- Regular cleaning is essential to avoid build up of these products on the surface.
- Avoid exposure to direct or prolonged periods of sunlight and position away from direct heat sources such as radiators.
- Care should be taken to avoid spilling anything on the upholstery. If a spillage occurs act promptly and soak up any liquids by blotting with a clean absorbent cloth. Never rub to remove stains. Never use a wet cloth.
- If a spillage does occur, blot any liquids immediately with a clean, dry absorbent cloth and allow to dry naturally.
- For more stubborn stains a professional upholstery cleaner should be consulted.
- Clean periodically in situ using a professional cleaning company.
- All assembly fixings should always be tightened properly and periodically check all fixings and tighten if necessary.

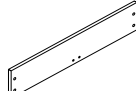
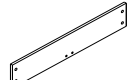
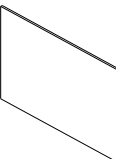
FITTINGS

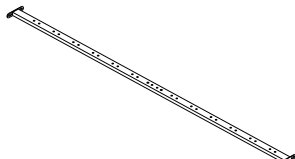
								
M8x80	M6x35	M6x25	M8x35	10*40	8x30		M8	
A x 8	B x 18	C x 4	D x 4	E x 4	F x 18	G x 8	H x 12	
								
M6			M6	M8			M6	
I x 22	J x 16	K x 16	L x 22	M x 8	N x 16	O x 32	P x 1	Q x 1

PARTS

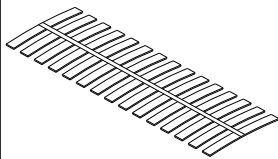
							
① × 1	② × 1	③ × 2	④ × 2	⑤ × 1	⑥ × 4	⑦ × 2	⑧ × 2
							
⑨ × 2	⑩ × 2	⑪ × 1	⑫ × 2	⑬ × 4	⑭ × 4	⑮ × 32	

STEP ONE

1. Screw 2 x legs 13 to headboard 1. Tighten with hand.

1. Screw 2 x legs 13 to headboard 2. Tighten with

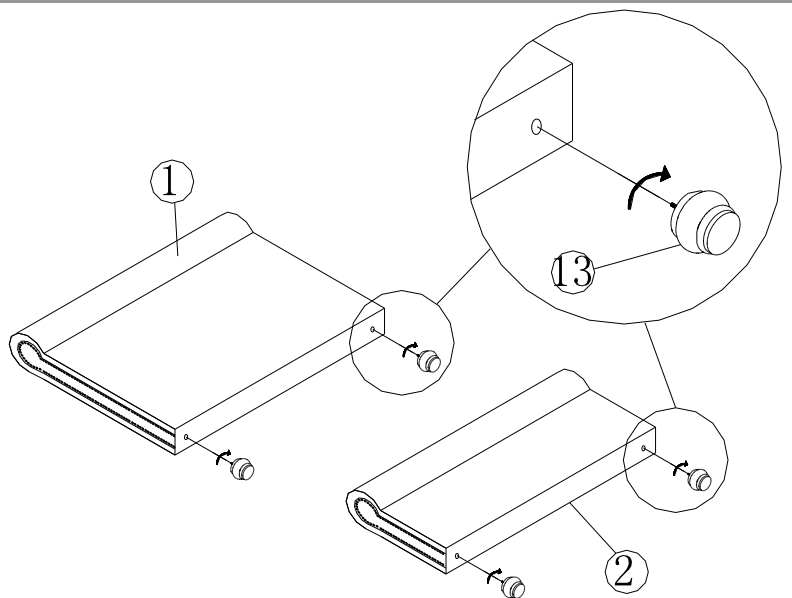

STEP TWO

1. Attach 2 x side rails 3 to headboard 1 using 4 x bolts (A), 2 x dowel (E), 4 x half moon washers (G) and 4 x nuts (H). Tighten with Spanner (Q).

2. Attach 2 x side rails 3 to footboard 2 using 4 x bolts (A), 2 x dowel (E), 4 x half moon washers (G) and 4 x nuts (H). Tighten with Spanner (Q).

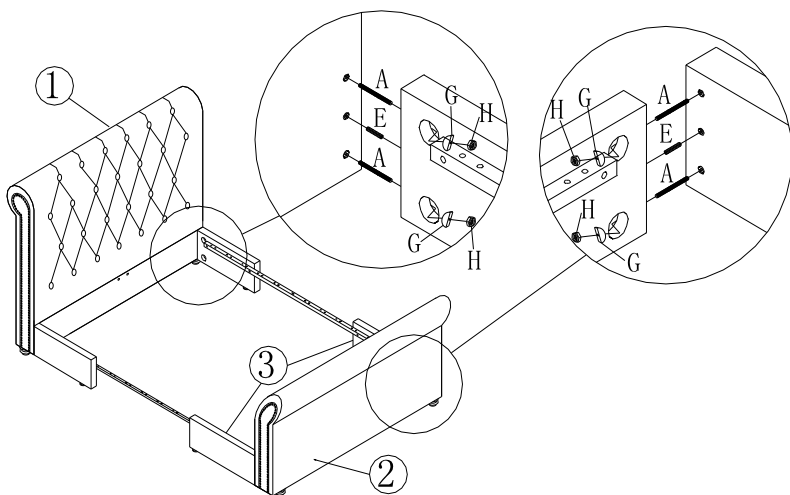

STEP THREE

1. Attach central support rail 11 to headboard 1 and footboard 2 with 4 x bolts (C), 4 x flat washers (I) and 4 x spring washers (L). Tighten with Allen key (P).

2. Attach 2 x central support leg 12 to central support rail 11 using 4 x bolts (D), 4 x nuts (H) and 8 x flat washers (M). Tighten with a crosshead screwdriver and spanner (Q).

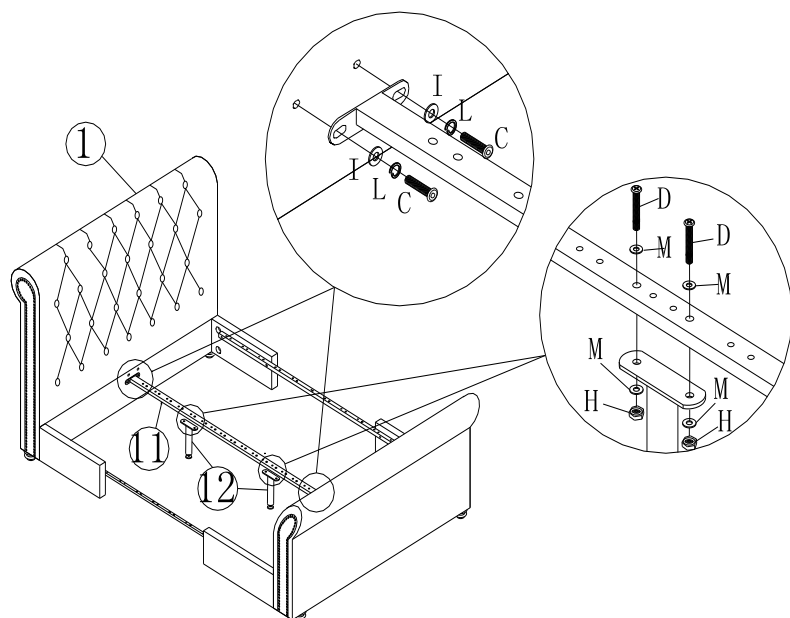

STEP FOUR

1. Attach drawer support rail 4 to side rail 3 with 8 x bolts (B), 8 x flat washers (I) and 8 x spring washers (L). Tighten with Allen key (P).

1. Attach drawer cross bar 5 to drawer support rail 4 with 2 x bolts (B), 2 x dowel (F), 2 x flat washers (I) and 2 x spring washers (L). Tighten with Allen key (P).

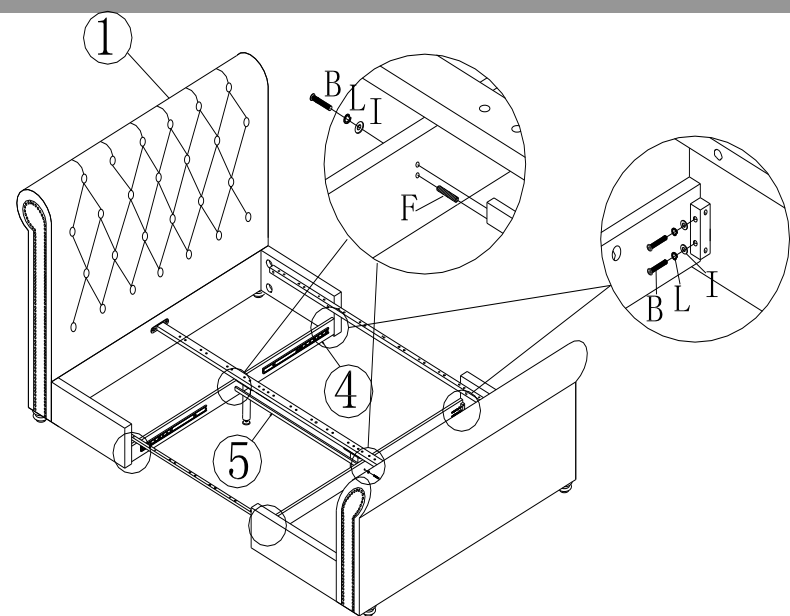

STEP FIVE

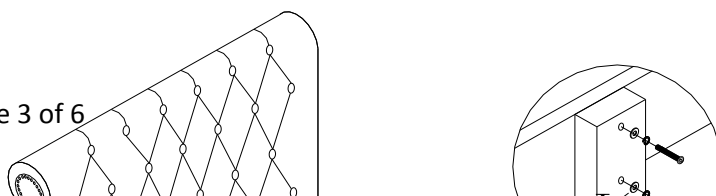

1. Attach wood support leg 14 to drawer support rail 4 with 8 x bolts (B), 8 x flat washers (I) and 8 x spring washers (L). Tighten with Allen key (P).

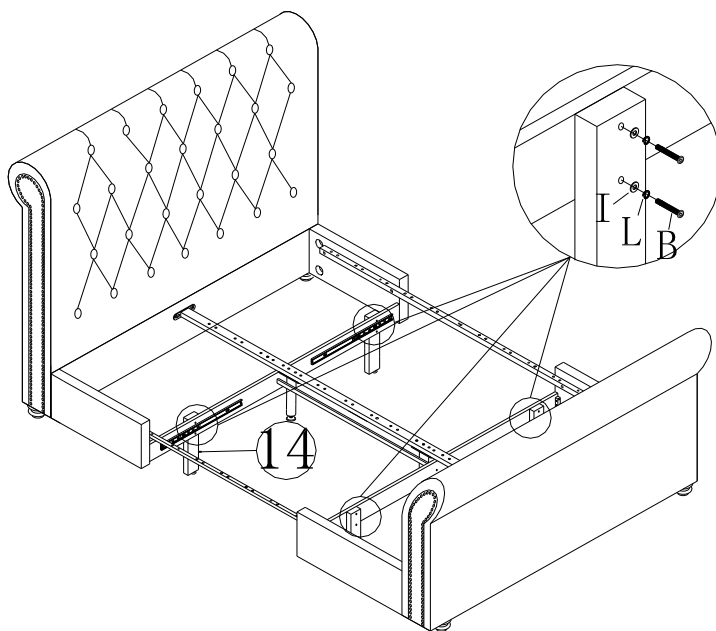

STEP SIX

1. Insert slats 15 into end caps (O) and double end caps (N) as shown.

2. Insert each end cap into corresponding holes in 2 x side rails 3 and central support rail 11. Repeat process for each slat.

NOTES:

- * The curve of the slat must be facing upwards.
- * Number of slats and caps vary dependant on size. Quantities as shown in FITTINGS and PARTS sections.

Note: Double 16 x Slats
King 16 x Slats
Super King 16 x Slats

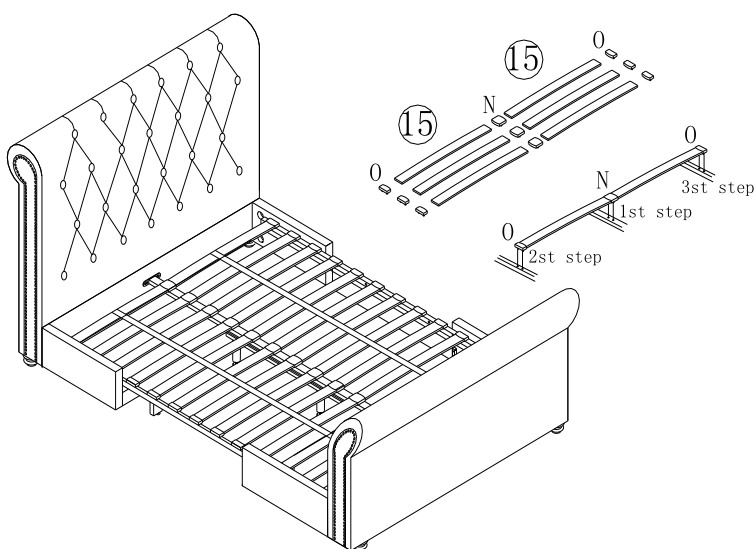

STEP SEVEN

1. Insert 8 x cam bolts (J) into drawer sides (x2) and tighten with a screwdriver.
2. Insert 4 x wooden dowels (F) into drawer sides (x2).
3. Attach drawer sides 6 (x2) to drawer back 8. Insert 4 x cam locks (K) into drawer back 8 and tighten with a screwdriver.
4. Repeat prior step to produce the remaining drawer frame using the remaining drawer sides 6 and drawer back 8.

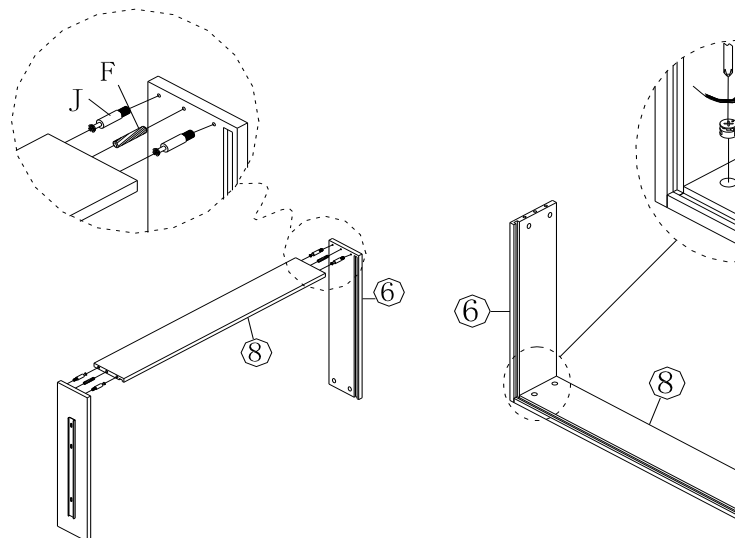

STEP EIGHT

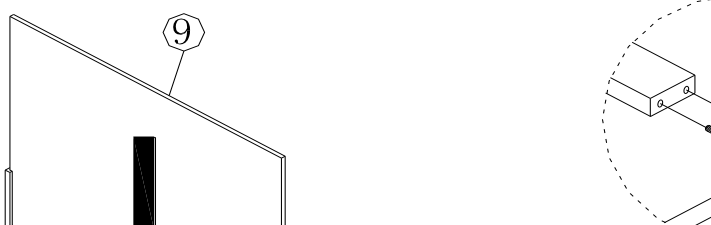

1. Carefully slide drawer bottoms 9 (x2) into each prior assembled drawer frame.

2. Attach drawer strength rail 10 (x2) to drawer back 8. Insert 4 x wooden dowels (F) into drawer back (x2).

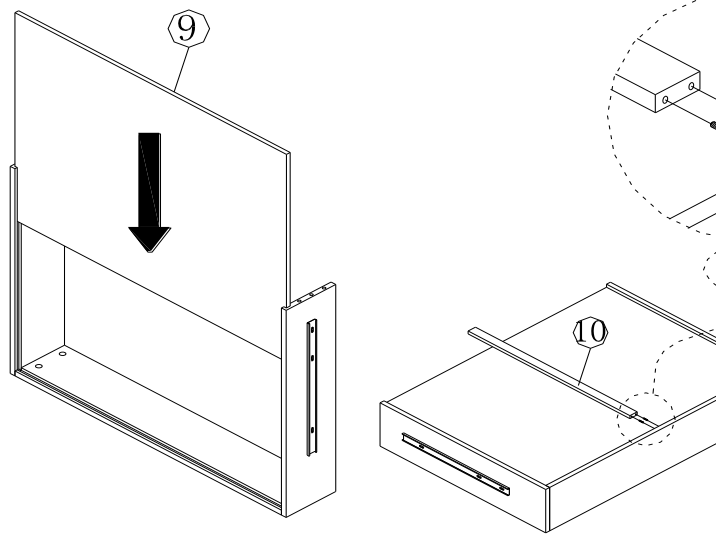

STEP NINE

1. Insert 8 x cam bolts (J) into drawer fronts 7 (x2) and tighten with a screwdriver.

2. Insert 4 x wooden dowels (F) into drawer fronts 7 (x2).

3. Attach drawer fronts 7 (x2) and 2 x wooden dowels (F) to assembled drawer frames.

4. Insert 8 x cam locks (K) into drawer sides 6 (x4) and tighten with a screwdriver.

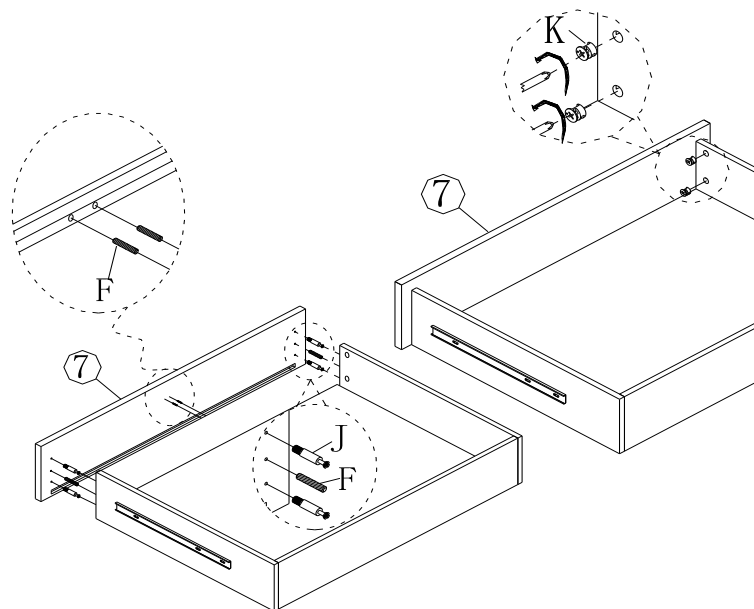

STEP TEN

Insert the assembled drawers into the bed.

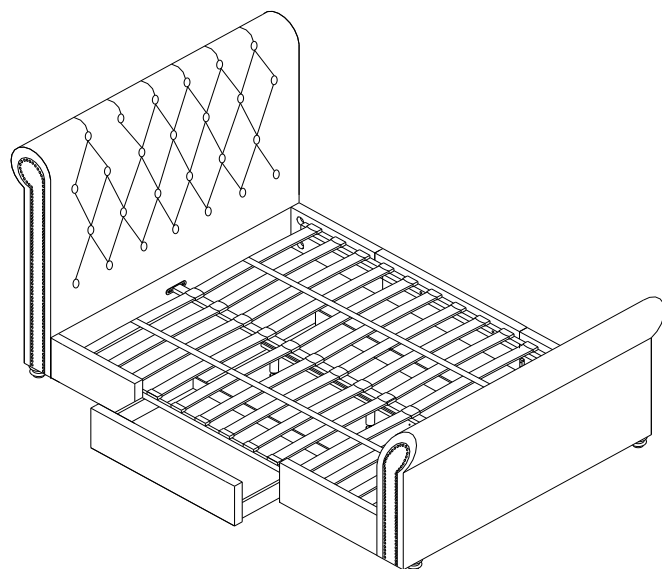

STEP ELEVEN

IMPORTANT

Once the footboard has been assembled and attached, there should be a distance between the footboard and the floor.

Once the feet have been assembled and attached, they should be adjusted to ensure they do not touch the floor, (5mm above the floor) to allow for movement once the mattress is placed on the bed frame.

It is important to note that when moving the bed that it is not dragged into its new position to prevent the possibility of these feet being twisted or angled to one side, which could lead to the collapse of the centre of the bed.

To move the bed, remove the mattress and lift the bed into its new position to avoid damage. Ensure the feet are at 90° to the floor before replacing the mattress.

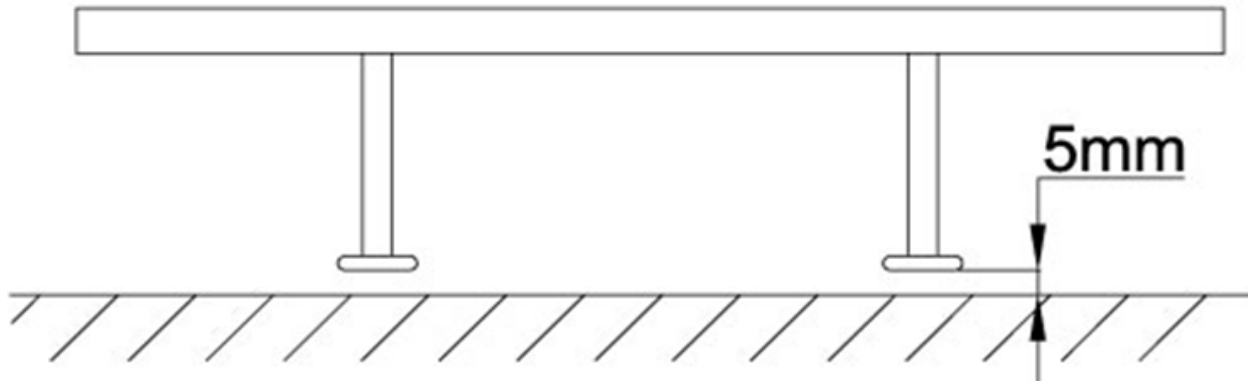

Next Retail Ltd, Desford Road, Leicester, LE19 4AT